

---

# VectorWorks Reference

Welcome to the VectorWorks 3D Power Pack™. The 3D Power Pack is an additional module that works with VectorWorks 9.5.1 to provide significantly expanded NURBS (Non Uniform Rational B-Splines) functionality.

NURBS is a mathematical formulation that represents the geometry of curves and surfaces in 3D space. In the previous version of VectorWorks, NURBS curves, circles, and arcs were available. The 3D Power Pack adds the new functionality of creating NURBS curves and surfaces to significantly increase the 3D operations possible in VectorWorks.

The 3D Power Pack provides the following features and benefits:

- Advanced solid modeling operations
- Advanced surface modeling operations
- Solid-surface interactions
- Participation of surfaces in Boolean operations
- Easy manipulation of surface geometry
- Simple 3D user interface

**To navigate to the topic you are interested in, either select it from the table of contents on the left, or use the Acrobat Find and Search features. A comprehensive index is also included, which can be accessed by clicking Index from the table of contents.**

---

© 2002 Nemetschek N.A., Incorporated. All Rights Reserved. Nemetschek N.A., Inc., hereafter referred to as NNA, and its licensors retain all ownership rights to the MiniCAD® VectorWorks® computer program and all other computer programs as well as documentation offered by NNA. Use of NNA software is governed by the license agreement accompanying your original media. The source code for such software is a confidential trade secret of NNA. You may not attempt to decipher, decompile, develop or otherwise reverse engineer NNA software. Information necessary to achieve interoperability with this software may be furnished upon request.

### **VectorWorks 3D Power Pack User's Guide**

This manual, as well as the software described in it, is furnished under license and may only be used or copied in accordance with the terms of such license. The information in this manual is furnished for informational use only, is subject to change without notice, and should not be construed as a commitment by NNA. NNA assumes no responsibility or liability for any errors or inaccuracies that may appear in this manual.

Except as permitted by such license, no part of this publication may be reproduced, stored in a retrieval system, or transmitted, in any form or by any means, electronic, mechanical, recording, or otherwise, without the express prior written permission of NNA.

Existing artwork or images that you may desire to scan or copy may be protected under copyright law. The unauthorized incorporation of such artwork into your work may be a violation of the rights of the author or illustrator. Please be sure to obtain any permission required from such authors.

MiniCAD, VectorWorks, and RenderWorks are registered trademarks of NNA. VectorScript, 3D Power Pack, SmartCursor, and the Design and Drafting Toolkit are trademarks of NNA.

The following are copyrights or trademarks of their respective companies or organizations:

Microsoft, Windows, Windows NT, Windows 2000, and Windows ME are registered trademarks of the Microsoft Corporation.

QuickTime and Macintosh are trademarks of Apple Computer, Inc.

All other brand or product names are trademarks or registered trademarks of their respective companies or organizations.

The VectorWorks 3D Power Pack User's Guide was written by TéAntáe Turner, Alexandra Duffy, Susan Collins, and Biplab Sarkar at Nemetschek N.A., Incorporated, 7150 Riverwood Drive, Columbia, MD, 21046, USA.

Cover design by Kathleen Ryland. Illustrations by TéAntáe Turner, Alexandra Duffy, Susan Collins, and Biplab Sarkar.

For Defense Agencies: Restricted Rights Legend. Use reproduction, or disclosure is subject to restrictions set forth in subparagraph (c)(1)(ii) of the Rights of Technical Data and Computer Software clause at 252.227-7013.

For civilian agencies: Restricted Rights Legend. Use, reproduction, or disclosure is subject to restrictions set forth in subparagraphs (a) through (d) of the commercial Computer Software Restricted Rights clause at 52.227-19. Unpublished rights reserved under the copyright laws of the United States. The contractor/manufacturer is Nemetschek N.A., Incorporated, 7150 Riverwood Drive, Columbia, MD, 21046, USA.

### **Registration & Updates**

The VectorWorks disks are warranted subject to the conditions of the License Agreement for a period of six (6) months from the date of purchase by the end user. A completed Registration Card must be returned to NNA to officially register your copy of VectorWorks.

Only registered users are entitled to technical support, the NNA newsletter, maintenance releases, and reduced cost upgrades.

Defective master disks are replaced free of charge to the end user for six (6) months after purchase. Thereafter, master disks will be replaced for a nominal service fee set by NNA.

NNA will make available from time to time upgrades to the purchased program for nominal charges. Such upgrades, along with the original master copy of the program, shall be considered one program, subject in its entirety to the License Agreement.

## **License Agreement**

NNA grants the buyer a non-exclusive license to use the software in the package according to the terms set forth below. The software is protected by copyright laws and international copyright treaties, as well as by other intellectual property laws and treaties.

This program has been purchased for a single, specific operating system per serial number. It is licensed for installation on one machine for each serial number.

### **The Buyer May:**

Install and operate this software on one computer at a time; make one back-up copy of the software, which is automatically subject to this agreement, and modify unprotected VectorScript routines provided with this software.

### **The Buyer May Not:**

- 1: Make this software available to any person or entity other than employees who must use this software as specified above.
- 2: Modify or merge the software with another program, except for personal use as described above.
- 3: Disassemble, decompile, reverse engineer, or attempt in any fashion to discover the source code of the software.
- 4: Sub-license, sell, lend, rent, or lease any portion of the software. The buyer may, after notifying NNA, permanently transfer all (but no portion thereof) of the software to another person or entity, who in turn is subject to this agreement.
- 5: Operate the software on more than one computer at a time. (Site licenses are available from NNA for multi-station use. All sites in a site license must be used at one location.)

NOTE: This software involves valuable proprietary rights of NNA and others. There is no transfer to the buyer of any title to, or ownership of, this software; nor is there transfer of any patent, copyright, trade secret, trade name, trademark, or other proprietary rights related to the software. The buyer may not violate these rights and must take appropriate steps to protect NNA's rights. NNA may at any time replace, modify, alter, improve, enhance, or change the software. The license and the buyer's right to use the software terminate automatically if the buyer violates any part of this agreement. In the event of termination of buyer's right to use the software, all copies of the software must be destroyed or immediately returned to NNA.

## **Upgrades:**

All upgrades or sequential versions of the program obtained under upgrade agreements or offered at a later date in consideration of this purchase will be considered one program under this license agreement. Under no circumstances will the providing of upgrades be considered as permission for this program to reside on more than one computer at any time, nor may the buyer sub-license, sell, lend, rent, or lease any portion of former versions of the software. Again, the license and the buyer's right to use the software terminate automatically if the buyer violates any part of this agreement. In the event of

termination of buyer's right to use the software, all copies of the software must be destroyed or immediately returned to NNA.

## **General:**

NNA is not responsible for maintaining the software or for helping the buyer in the use of said software except through the Registered User Support Service. This agreement constitutes the entire agreement and supersedes any prior agreement between NNA and the buyer.

# Table of Contents

- VECTORWORKS REFERENCE ..... 1-1**
  
- VECTORWORKS 3D POWER PACK..... 1-1**
  - OVERVIEW ..... 1-1
    - 3D POWER PACK WORKSPACE ..... 1-1
    - 3D POWER PACK TOOLS AND COMMANDS ..... 1-1
    - 3D POWER PACK COMPATIBILITY ..... 1-3
    - 3D POWER PACK CURSORS ..... 1-3
    - SELECTING THE EDGES AND FACES OF A SOLID ..... 1-3
    - EDITING A FILLET/CHAMFER OR SHELL OBJECT ..... 1-6
    - SURFACE GEOMETRY REQUIREMENTS ..... 1-7
  - NURBS CURVES ..... 1-7
    - EXTRACTING CURVES ..... 1-7
    - CREATING CONTOURS ..... 1-8
    - CURVE MATCHING ..... 1-9
  - NURBS SURFACES ..... 1-11
    - CONVERTING TO NURBS ..... 1-11
    - EXTRACTING A NURBS SURFACE FROM A SOLID ..... 1-12
    - CREATING A LOFT SURFACE ..... 1-13
    - CREATING SURFACES FROM CURVES ..... 1-16
    - CREATING A FILLET SURFACE ..... 1-19
    - CREATING PLANAR CAPS ..... 1-20
    - RESHAPING SURFACES ..... 1-21
    - NURBS SURFACE PROPERTIES ..... 1-23
    - COMPOSING SURFACES ..... 1-25
    - DECOMPOSING SURFACES ..... 1-25
    - SPLITTING NURBS SURFACES ..... 1-26
  - NURBS SURFACE-CURVE INTERACTION ..... 1-29
    - TRIMMING NURBS SURFACES WITH A PROJECTION ..... 1-29
  - SOLIDS OPERATIONS ..... 1-30
    - BLENDING EDGES ..... 1-30
    - CREATING A SHELL FROM A SOLID OBJECT ..... 1-33
    - CREATING A TAPERED EXTRUDE ..... 1-35
    - STITCHING AND TRIMMING SURFACES ..... 1-36
    - SECTIONING SOLIDS ..... 1-37

---

EXPORTING IN 3D POWER PACK .....	1-38
EXPORTING IN IGES FORMAT (3D ONLY).....	1-38
<b>EXTRACTING CURVES FROM SOLIDS .....</b>	<b>2-1</b>
SETTING UP THE MODELING UNITS .....	2-1
CREATING A BLOCK .....	2-1
BLENDING EDGES .....	2-2
HOLLOWING OUT THE BLOCK .....	2-3
EXTRACTING CURVES .....	2-4
CREATING THE GROOVE .....	2-5
<b>CREATING AND MODIFYING NURBS SURFACES .....</b>	<b>3-1</b>
SETTING UP THE MODELING UNITS .....	3-1
CREATING A BLOCK .....	3-1
CREATING NURBS SURFACES.....	3-2
RESHAPING THE NURBS SURFACE.....	3-2
CREATING THE SOLID.....	3-3
SMOOTHING THE EDGES .....	3-4
<b>CREATING SURFACE MODELS .....</b>	<b>4-1</b>
SETTING UP THE MODELING UNITS .....	4-1
CREATING A FLAT NURBS SURFACE .....	4-1
RESHAPING THE NURBS SURFACE.....	4-2
CREATING A TRIMMED SURFACE .....	4-3
CREATING THE HAT SHAPE .....	4-3
<b>CREATING AND MODIFYING FREE-FORM SHAPES .....</b>	<b>5-1</b>
SETTING UP THE MODELING UNITS .....	5-1
CREATING THE CROSS SECTIONS.....	5-1
SETTING UP THE CROSS SECTION.....	5-2
CREATING THE VASE SHAPE .....	5-4
HOLLOWING OUT THE VASE .....	5-6

# VectorWorks 3D Power Pack



## Overview

### 3D Power Pack Workspace

To access the 3D Power Pack menus and tools, select **File > Workspaces > Standard 3D Power Pack**. The 3D Power Pack workspace opens.

### 3D Power Pack Tools and Commands

Several new tools and commands have been added to the 3D Power Pack workspace. Other tools and commands have been modified to take advantage of the new NURBS functionality.

#### In this Chapter:

- Overview
- NURBS Curves
- NURBS Surfaces
- NURBS Surface-Curve Interaction
- Solids Operations
- Exporting in 3D Power Pack

Name	Purpose	Location
Extract Curve tool	Extracts NURBS curves from the edges of a solid	“Extracting Curves” on page 1-7
Create Contours tool	Creates contours at specified intervals	“Creating Contours” on page 1-8
Connect/Combine tool	Three new options for dual object connect/combine have been added to this modified tool	“Curve Matching” on page 1-9
Convert to NURBS command	This command has been modified to include the conversion of solids faces to NURBS surfaces	“Converting to NURBS” on page 1-11
Extract Surface tool	Extracts NURBS surfaces from the faces of a solid	“Extracting a NURBS Surface from a Solid” on page 1-12
Loft Surface tool	Creates one or more NURBS surfaces from two or more cross-sections	“Creating a Loft Surface” on page 1-13
Create Surface from Curves command	Creates a NURBS surface from a network of intersecting NURBS curves	“Creating Surfaces from Curves” on page 1-16

<b>Name</b>	<b>Purpose</b>	<b>Location</b>
Create Fillet Surface command	Creates a surface tangential to two selected surfaces	“Creating a Fillet Surface” on page 1-19
Create Planar Caps command	Creates planar NURBS surfaces to cap the holes in a solid	“Creating Planar Caps” on page 1-20
3D Reshape tool	This tool has been modified to manipulate NURBS surface control points	“Reshaping Surfaces” on page 1-21
Compose command	Formerly the Compose Curve command, the modified Compose command can now handle NURBS surfaces	“Composing Surfaces” on page 1-25
Decompose command	Formerly the Decompose Curve command, the modified Decompose command can now handle NURBS surfaces	“Decomposing Surfaces” on page 1-25
Split tool	This tool has been modified to split NURBS surfaces and solids by point or line	“Splitting NURBS Surfaces” on page 1-26
Project and Trim tool	Trims a surface by projecting a curve on it	“Trimming NURBS Surfaces with a Projection” on page 1-29
Blend Edge tool	Creates a fillet or chamfer to remove the sharp corners of a solid	“Blending Edges” on page 1-30
Shell Solid tool	Creates a thin shell from a solid object	“Creating a Shell from a Solid Object” on page 1-33
Tapered Extrude command	This command has been modified to create tapered extrudes from NURBS curves and 3D polygons	“Creating a Tapered Extrude” on page 1-35
Stitch and Trim Surfaces command	Creates a group of trimmed NURBS surfaces from several intersecting NURBS surfaces	“Stitching and Trimming Surfaces” on page 1-36
Section Solids command	Solids can be sectioned by a surface, discarding the geometry on one side of the sectioning surface	“Sectioning Solids” on page 1-37
Export IGES command	Exports NURBS curves, surfaces, and solids from VectorWorks	“Exporting in IGES Format (3D only)” on page 1-38
Flyover Boomerang mode	To obtain the flyover tool in Pause/Boomerang mode, press spacebar + B. Release the spacebar + B to return to the 3D Power Pack tool.	Applies to all version 9.5.1 tools

## 3D Power Pack Compatibility





All geometry created with the 3D Power Pack is supported in VectorWorks 9.5.1, including versions of VectorWorks 9.5.1 without the Power Pack module installed.

All Power Pack operations, with the exception of blends, shells, and section solids, are supported in previous releases of VectorWorks 9. Objects with blended edges, shells, and section solids are deleted in versions of VectorWorks prior to 9.5.1.

3D Power Pack geometry is not supported in versions of VectorWorks prior to version 9.

## 3D Power Pack Cursors

Several new cursors have been introduced in the 3D Power Pack. These appear during certain operations to help determine the current mouse function; they do not display when an active selection is about to occur.

Cursor/Operation	Tool Where Used
Edge Selection 	<b>Extract Curve</b> tool and <b>Blend Edge</b> tool
Face Selection 	<b>Extract Surface</b> tool and <b>Shell Solid</b> tool, as well as the <b>Blend Edge</b> tool with Select Faces option turned on
Curve Selection 	<b>Loft Surface</b> tool and <b>Project and Trim</b> tool
Surface Selection 	<b>Project and Trim</b> tool

## Selecting the Edges and Faces of a Solid

Several 3D Power Pack tools require the selection of edges or faces of a solid. The **Extract Curve** tool requires edge selection, while the **Extract Surface** and **Shell Solid** tools require face selection. The **Blend Edge** tool can require both face and edge selection, depending upon the option selected in Blend Edge Preferences dialog box.

## Selecting Edges

An edge is selected by clicking on that edge. When you are near an edge, the cursor changes to an arrowhead. This is an indication that you are on an object that you can select by clicking on it. If there is more than one edge near the cursor, the nearest edge is selected.

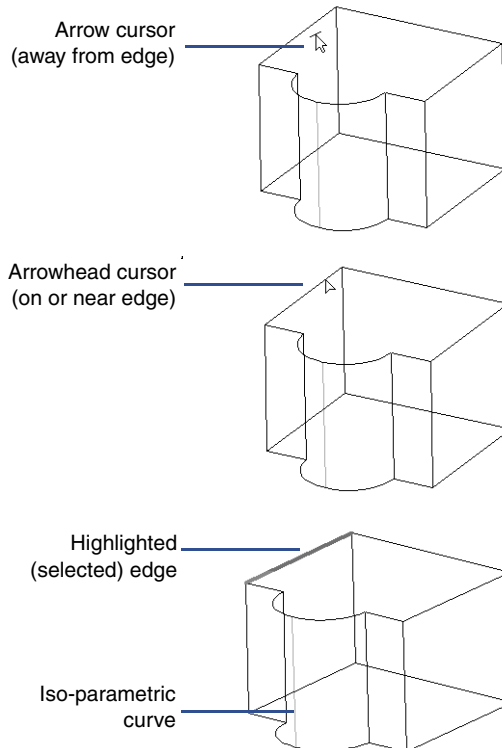

The cursor changes to an arrowhead when you are on or near an edge, or an iso-parametric curve drawn in lighter shade of the pen color of the solid. In the above solid, the iso-parametric curves are drawn in light gray. Although the cursor changes near these curves, these curves cannot actually be selected. Only edges displayed in a dark color can be selected.

- |  |  |
|--|--|
| <b>To select more than one edge</b>                  | Press the Shift key and select the edges                                   |
| <b>To deselect a selected edge</b>                   | Click on the edge again with the Shift key pressed                         |
| <b>To deselect the edges that have been selected</b> | Click on an empty area   |
| <b>To deselect the last selection</b>                | Press the Backspace (Win) or Delete (Mac) key, or double-click on the edge |

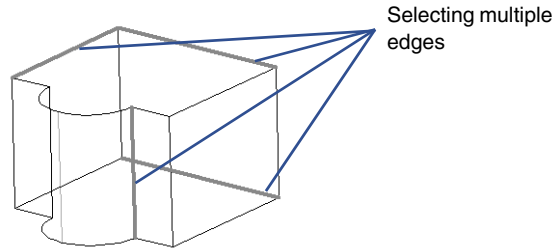

## Selecting Faces

Face selection in VectorWorks is actually an edge-based selection. When you are on an edge or near an edge or near an iso-parametric curve, you can select the face on either side of the edge depending on the cursor position.

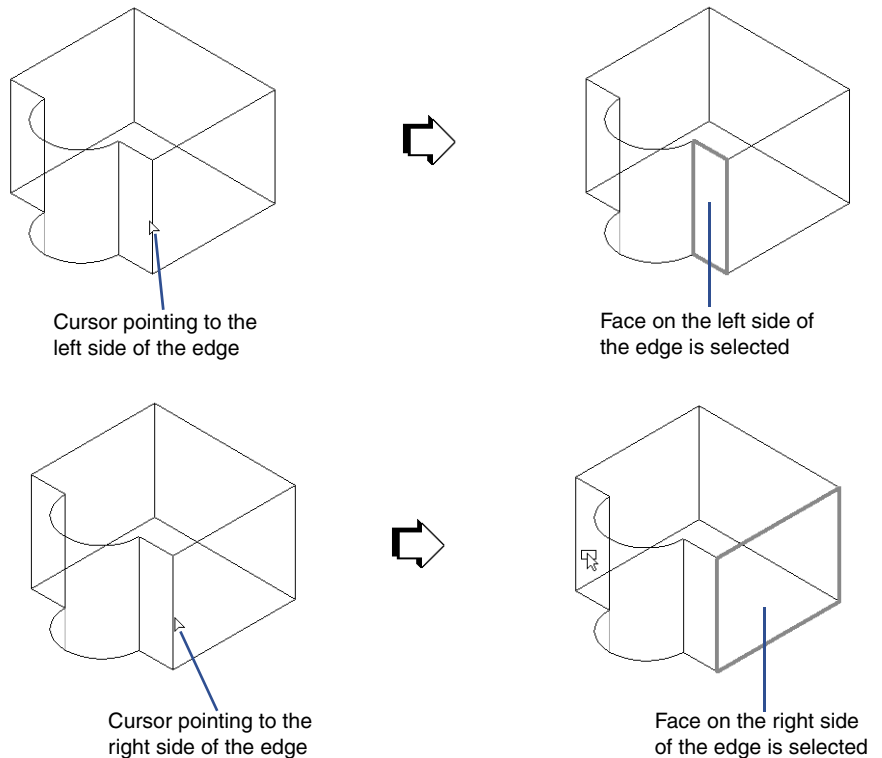

If the cursor is positioned over more than one face, or near an iso-parametric curve on a face, the Select Face dialog box opens to specify which face to select.

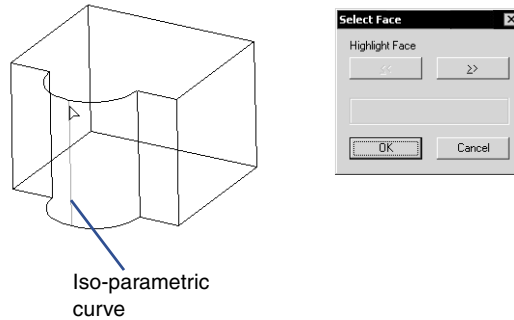

Click the arrow keys until the desired face is selected. Click **OK** to select the face.

Multiple faces can be selected while pressing the Shift key, much like the edge selection described earlier. Deselecting faces is also similar to deselecting edges.

## Editing a Fillet/Chamfer or Shell Object

A fillet, chamfer, or shell object follows certain editing conventions.

The set of edges or faces used to create the fillet/chamfer or shell cannot be changed once the operation is performed; edges or faces cannot be deleted from or added to the existing set. To add or delete edges or faces, first ungroup the object, and then perform the operation again.

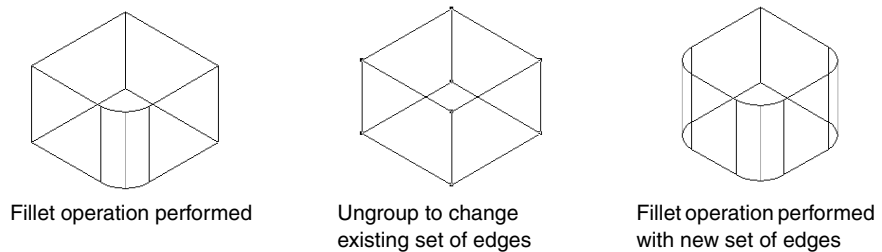

The properties that *can* be changed from the Object Info palette include the thickness of a shell, the radius of a fillet or setback distance of a chamfer. However, only the parameters of the topmost object can be changed.

For example, if a shell is created, and then some of the shell edges are filleted, only the fillet parameters can be changed directly from the Object Info palette. To change the shell thickness, the fillet object must first be ungrouped. To change the original extrusion, both the fillet and the shell must be ungrouped. Once changes have been made, reapply the shell and fillet.

**Note:** The **Organize > Edit Group** command cannot be used for these objects. The history of these objects is not retained; therefore, they cannot be regenerated automatically.

## Surface Geometry Requirements

Some surface geometry can contain degenerate patches, singularities, or self-intersections. These types of surfaces could potentially be produced with the **3D Reshape** tool, **Loft Surface** tool, or **Create Surface from Curves** command, and can produce undesirable results in the finished model. Surface operations, such as stitch/trim and split, and other operations, like creating contours and solid operations, may not be able to manipulate these types of surfaces.

## NURBS Curves

### Extracting Curves



Extract Curve Tool

The **Extract Curve** tool extracts a NURBS curve from the edge of a solid object, leaving the original unmodified. The extracted curves can then be used for other surface operations.

To extract a NURBS curve from the edge of a solid object:

1. In the desired view, click the **Extract Curve** tool from the 3D Tools palette.
2. Holding the Shift key, select the edge(s) of the object to be extracted.

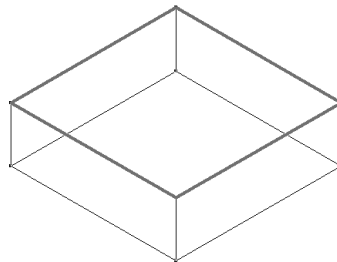

3. Press Enter (Win) or Return (Mac) or the check mark button on the Mode bar to extract the selected NURBS curves.

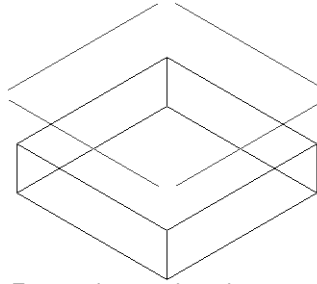

Extracted curves have been ungrouped and moved for clarity

**Note:** To edit the curve(s), select **Organize > Ungroup**.

## Creating Contours



Create Contours Tool

Contours are intersections of a solid or surface with a plane passing through the line specified with the **Create Contours** tool. This tool creates contours at specified intervals, which can then be used to create a loft surface in order to recreate a solid shape.

To create contours:

1. Click the **Create Contours** tool from the 3D Tools palette.
2. Click the Preferences button on the Mode bar to specify the contour interval.

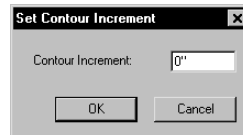

3. Click and drag to indicate the position of the intersecting plane.

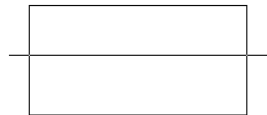

The contours, a group of NURBS curves, are drawn in red.

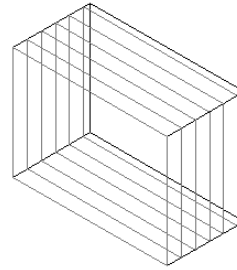

## Curve Matching



Connect/Combine Tool

The **Connect/Combine** tool joins objects by their endpoints or at their intersections using one of three modes: Single Object Connect, Dual Object Connect, or Dual Object Combine.

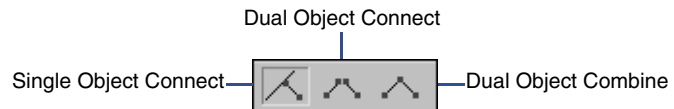

When connecting or combining a pair of NURBS, polylines, or open polygons by their endpoints, VectorWorks may require additional information to complete the process. In this situation, the Connect/Combine Options dialog box opens.

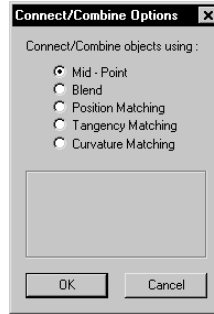

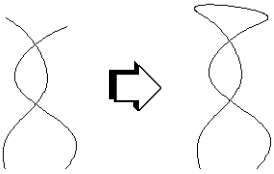
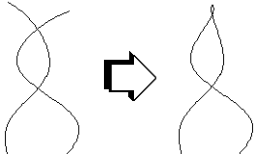
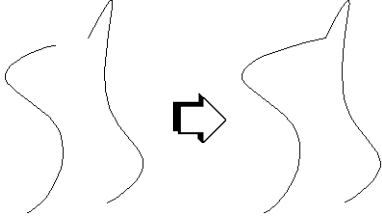
Option	Description
Mid-Point	<p>Connects/combines the two objects by joining the two endpoints midway between them</p> 
Blend	<p>Connects/combines the two objects by creating another object between them</p> 
Position Matching (NURBS curves only)	<p>Connects/combines two NURBS curves by moving the first object's selected end point to the selected end point of the boundary object. Not available if the end points are coincident.</p> 

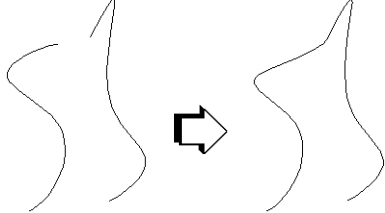
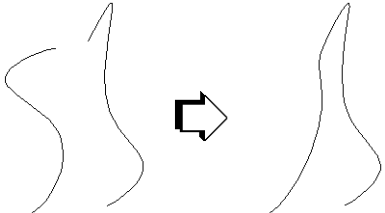
Option	Description
Tangency Matching (NURBS curves only)	Connects/combines two NURBS curves by making the first object's selected end point tangent with the selected end point of the boundary object  
Curvature Matching (NURBS curves only)	Connects/combines two NURBS curves by making the first object's selected end point match the curvature of the selected end point of the boundary object  

The **Connect/Combine** tool modes are described in the VectorWorks User's Guide.

## NURBS Surfaces

### Converting to NURBS

In addition to the previous behavior of converting 2D curves to NURBS curves, the **Convert to NURBS** command now converts the faces of solids to NURBS surfaces. This is a quick way of creating NURBS surfaces from an extrusion, sweep, or other solids.

To convert to NURBS surfaces:

1. Select the solid to convert to NURBS surfaces.

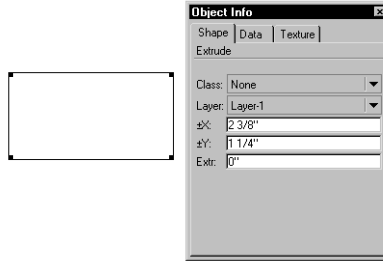

## 2. Select **Model > Convert to NURBS**.

The selection is converted to NURBS surface(s).

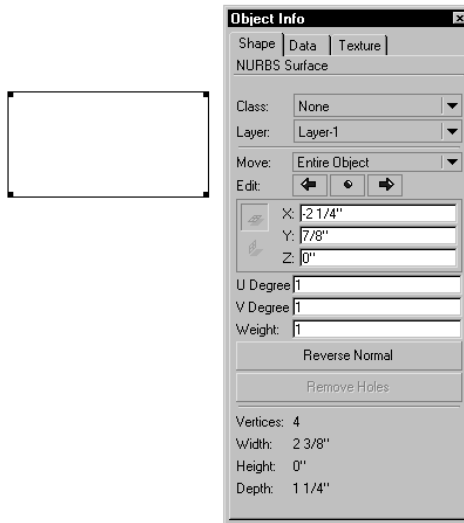

**Note:** *If the solid consisted of several faces, the result of the conversion will be a group of NURBS surfaces. Select **Organize > Ungroup** to access the individual NURBS surfaces that make up the solid.*

## Extracting a NURBS Surface from a Solid



Extract Surface  
Tool

The **Extract Surface** tool extracts NURBS surfaces from the faces of a solid, leaving the original object unmodified. The extracted NURBS surface can be used for sectioning solids or for stitch/trim surfaces.

To extract the surface from a solid:

1. Click the **Extract Surface** tool from the 3D Tools palette.

2. Select one or more faces to be extracted.

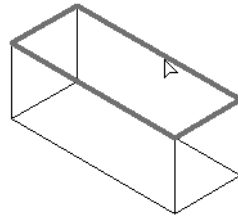

**Note:** See “Selecting the Edges and Faces of a Solid” on page 1-3 for information on selecting surfaces.

3. Press the Enter (Win) or Return (Mac) key or the check mark button on the Mode bar to extract the surface.

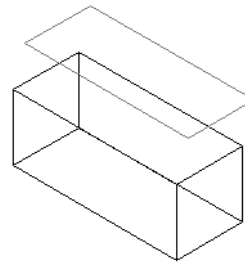

Surface moved for clarity

The extracted NURBS surface is displayed in red.

## Creating a Loft Surface



Loft Surface Tool

The **Loft Surface** tool creates a complex NURBS surface(s) from two or more cross sections. Similar to the **Multiple Extrude** command, the **Loft Surface** tool creates a 3D object from a series of other objects. Unlike **Multiple Extrude**, the cross sections do not need to be equally spaced, and the resulting profile can be manipulated to avoid self-intersection and to control twist.

**Note:** *This tool can potentially create surfaces which cannot be further manipulated in the 3D Power Pack. See “Surface Geometry Requirements” on page 1-7.*

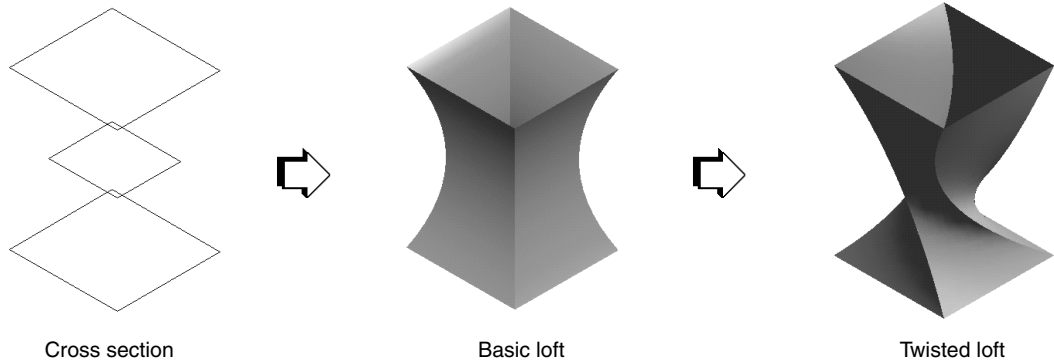

To create a NURBS surface from two or more cross sections:

1. Click the **Loft Surface** tool from the 3D Tools palette.
2. Click on each cross section. The cursor changes into an arrowhead when over a valid cross section. The point nearest to the click is selected.

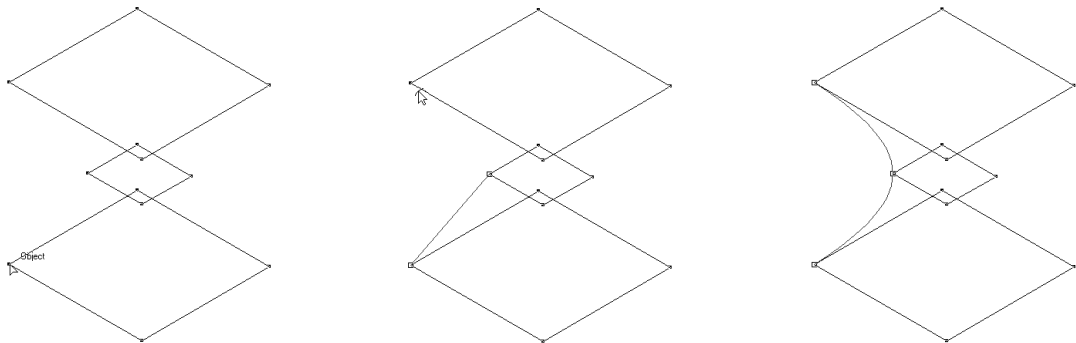

The proposed curve alignment displays in red as each section is selected.

**Note:** *Cross sections are created using NURBS curves which do not need to be the same shape or planar. Curves must be either closed or open objects, not a mixture of the two. 3D loci can be used in a loft but must appear at the ends of the loft.*

3. Once all curves are selected, press Enter (Win) or Return (Mac) or the check mark button on the Mode bar.

The Loft Creation dialog box opens.

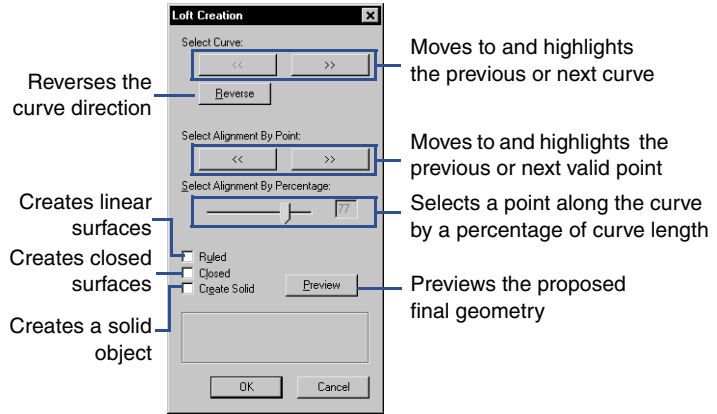

4. Specify the desired loft creation settings.

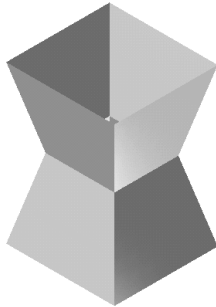
Parameter	Description
Select Curve	Selects the previous or next cross-section curve. <b>Reverse</b> changes the direction of the curve to twist or untwist the loft surface.
Select Alignment by Point	Selects the previous or next point on the selected cross section curve. If the cross section does not have any corners, this option is disabled.
Select Alignment by Percentage	Selects points along a geometrically-continuous cross section (circle, oval, etc.) by a specified percentage, or by adjusting the slider
Ruled	Creates a linearly-interpolated object 

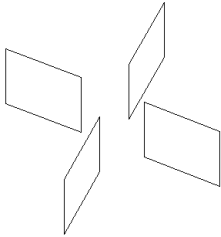
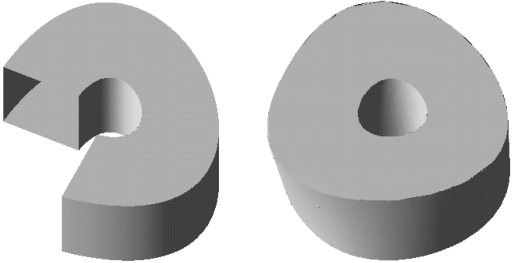
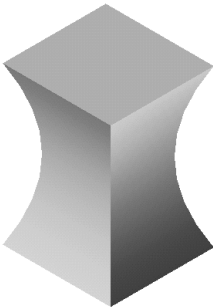
Parameter	Description
<p data-bbox="418 215 489 239">Closed</p>  <p data-bbox="475 623 605 647">Cross section</p>	<p data-bbox="725 215 1246 331">Creates a loof surface that closes in on itself. As the start point cannot be selected as the end point of a loof, the <b>Closed</b> option automatically completes the connection.</p>  <p data-bbox="718 623 903 675">Loof surface without Closed option</p> <p data-bbox="986 623 1229 675">Cross section with Closed option</p>
<p data-bbox="418 701 539 725">Create Solid</p>	<p data-bbox="725 701 1229 753">Creates a loof surface whose ends are capped and all surfaces are stitched together to create a solid object</p> 
<p data-bbox="418 1112 496 1137">Preview</p>	<p data-bbox="725 1112 1189 1164">Displays the proposed loof surfaces based on the current settings</p>

5. Click **OK** to close the dialog box and create the loof surface(s).

## Creating Surfaces from Curves

The **Create Surface from Curves** command creates a NURBS surface from a network of single closed curves (including closed 2D objects) or two or more open NURBS curves. These NURBS curves can be planar or non-planar, but NURBS in the U direction must intersect NURBS in the V direction at only one point.

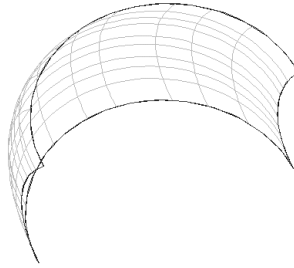

**Note:** *This command can potentially create surfaces which cannot be further manipulated in the 3D Power Pack. See “Surface Geometry Requirements” on page 1-7.*

To create a NURBS surface from curves:

1. Draw two or more open NURBS curves to create an enclosed region.



2. Select the NURBS objects being used to create the NURBS surface.
3. Select **Model > Create Surface from Curves**.

A NURBS surface is created with a red pen color.

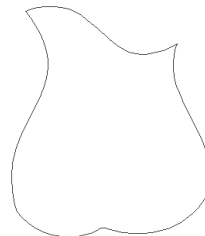

**Note:** *Multiple open NURBS that form both boundary and interior curves can be used to create a NURBS surface, but must have an equal number of intersections.*

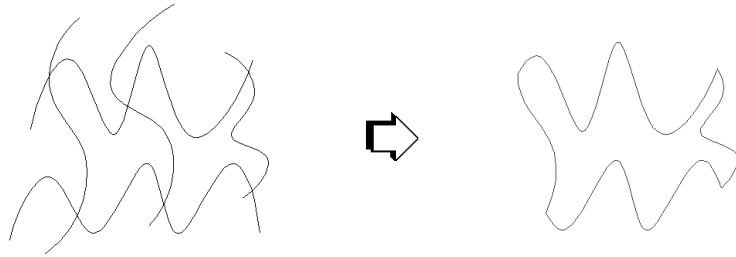

A NURBS surface is not created if:

There is more than one intersection, creating multiple enclosed regions

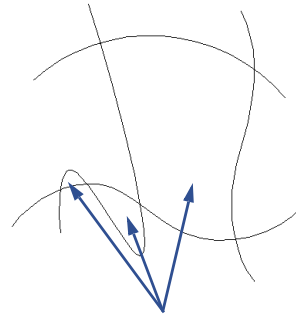

Only one enclosed region allowed

There is an intersection between curves in the same parametric direction

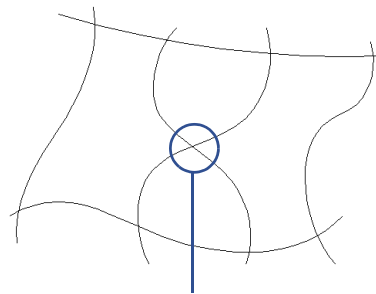

Intersection between curves in the same parametric direction

There are an unequal number of intersections

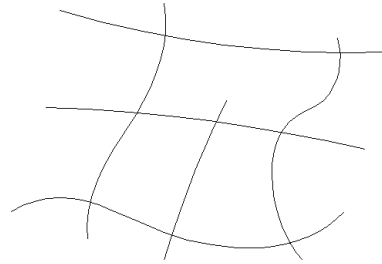

Unequal number of intersections

## Creating a Fillet Surface

The **Create Fillet Surface** command creates a surface tangential to two selected surfaces, leaving the original surfaces unmodified.

This command is useful for sheet metal design (e.g. for car bodies) to provide a smooth transition between two adjacent surfaces – perhaps for aesthetic quality or because of a manufacturing requirement.

To create a surface tangential to two selected surfaces:

1. Select two NURBS surfaces to create the filleted surface.

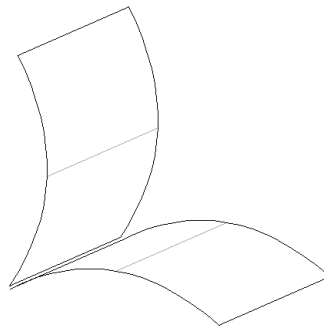

2. Select **Model > Create Fillet Surface**.

The Set Fillet Radius dialog box opens.

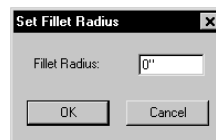

3. Enter the desired **Fillet Radius**, and then click **OK**.

A NURBS surface is created tangentially between the two objects.

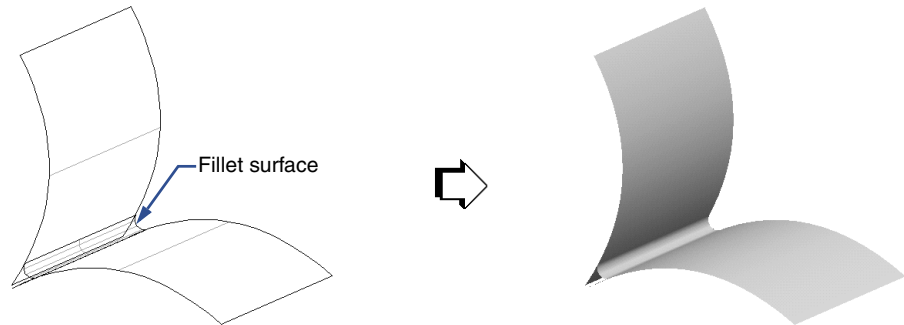

The resulting fillet can then be used to create a seamless join between NURBS surfaces.

To create a seamless join between NURBS surfaces:

1. Select all NURBS surfaces, and then select **Model > Add Solids** to add the fillet surface to the NURBS surface.
2. With the surfaces still selected, select **Model > Convert to NURBS** to convert all the surfaces of the solid to NURBS surfaces.
3. Select **Organize > Ungroup** to display all individual surfaces.
4. Click on the drawing area to deselect the objects. Delete the surfaces that are not to be used in the final object.

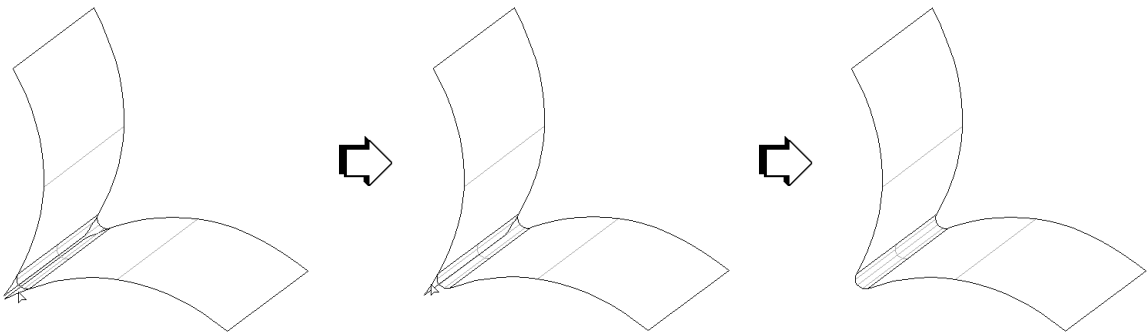

### Creating Planar Caps

The **Create Planar Caps** command closes off the ends of open-ended solids by creating planar NURBS surfaces. These surfaces can then be added to the rest of the surfaces with the **Add Solids** command.

To create planar caps:

1. Select the open-ended solid.

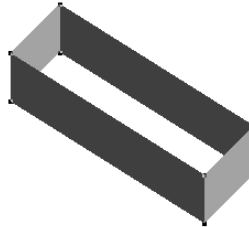

2. Select **Model > Create Planar Caps**.

Planar NURBS surfaces are created to close off the ends of the solid.

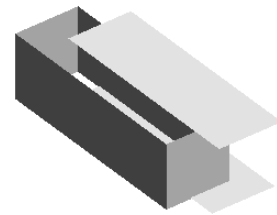
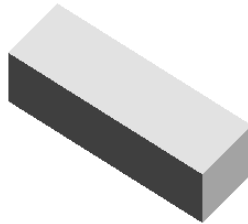

Planar caps moved for clarity

3. Add the solid and the planar cap surfaces by selecting them all and choosing **Model > Add Solids**.



3D Reshape Tool

## Reshaping Surfaces

The **3D Reshape** tool, located on the 3D Tools palette, can now be used to manipulate NURBS surface control points.

NURBS surfaces can be reshaped with this tool. For example, a dome or bell curve effect can be created by manipulating the vertices.

**Note:** *This tool can potentially create surfaces which cannot be further manipulated in the 3D Power Pack. See “Surface Geometry Requirements” on page 1-7.*

To reshape a NURBS surface:

1. Select the NURBS surface to reshape.

- Click the **3D Reshape** tool from the 3D Tools palette.

Select the mode from the Mode bar.

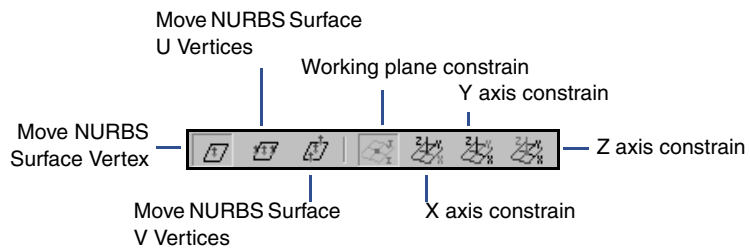

<b>Move NURBS Surface Vertex</b>	Changes the position of the selected vertex or vertices only
<b>Move NURBS Surface U Vertices</b>	Changes the position of all vertices in a row in the U direction
<b>Move NURBS Surface V Vertices</b>	Changes the position of all vertices in a row in the V direction
<b>Working plane constrain</b>	Moves the selected vertex or vertices on a working plane
<b>X axis constrain</b>	Moves the selected vertex or vertices along the x axis
<b>Y axis constrain</b>	Moves the selected vertex or vertices along the y axis
<b>Z axis constrain</b>	Moves the selected vertex or vertices along the z axis

If one vertex or row of vertices is to be selected, position the cursor over one of the NURBS surface vertices. When the cursor is over a vertex, the standard arrow cursor changes to an unfilled, four-way arrow.

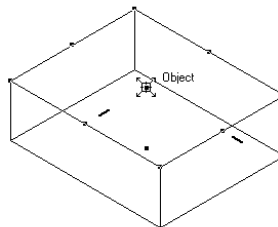

Several vertices can be selected at one time by clicking with the Shift key pressed or by drawing a marquee around the desired vertices.

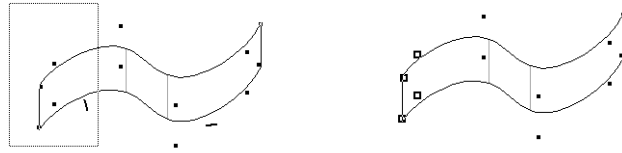

If several vertices are selected, position the cursor over one of them.

3. Click-drag the mouse to move the vertex or vertices.

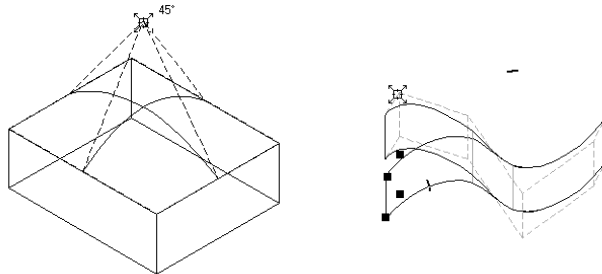

One vertex selected and moved

A group of vertices selected and moved

4. Release the mouse at the desired location.

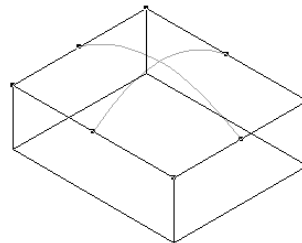

## NURBS Surface Properties

The properties of a NURBS surface are displayed in the Object Info palette, where they can also be edited.

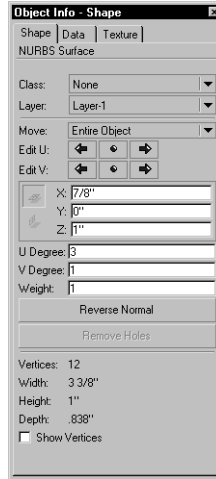

Parameter	Description
Move	Select <b>Entire Object</b> to edit all the vertices of the surface, <b>Vertex Only</b> to edit only the selected vertex, <b>U Vertices</b> to edit all of the vertices in a row in the U direction, and <b>V Vertices</b> to edit all of the vertices in a row in the V direction
Edit U/V	Scrolls through the vertices of the selected NURBS surface in either the U parametric direction or V parametric direction
X, Y, Z / I, J, K	Depending on the selection in the <b>Move</b> pulldown list, displays the position of the current surface or vertex; edit the values to change the surface/vertex position
U Degree	Degree in the U parametric direction; increasing this value adds vertices that can then be manipulated
V Degree	Degree in the V parametric direction; increasing this value adds vertices that can then be manipulated
Weight	NURBS curves and surfaces are represented mathematically by weighted control points. The weight value can be anywhere between .01 and 100. A weight above 1 pulls the curve or surface towards the control point; a weight below 1 has the reverse effect.
Reverse Normal	Flips the surface normal direction
Remove Holes	Removes the holes in a trimmed NURBS surface
NURBS Surface parameters (display only)	Displays the NURBS surface parameters
Show Control Points	Select the checkbox to display the surface's control points

## Composing Surfaces

The **Compose** command (formerly called the **Compose Curve** command) can now combine several NURBS surfaces into one. In addition, as it did previously, this command can compose 2D lines, arcs, open polygons, NURBS curves, NURBS arcs, and open 3D polygons.

Adjacent NURBS surfaces, which may have been split by the **Split** tool (see “Splitting NURBS Surfaces” on page 1-26), can be composed into a single NURBS surface with this command.

To compose adjacent NURBS surfaces:

1. Select the NURBS surfaces to be composed.

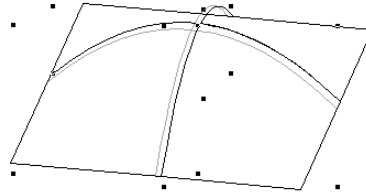

2. Select **Tool > Compose**. The objects are combined to create a single NURBS surface.

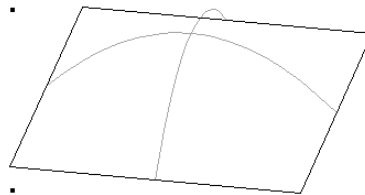

## Decomposing Surfaces

The **Decompose** command (formerly called the **Decompose Curve** command) can now decompose NURBS surfaces. In addition, as it did previously, this command can decompose 2D polygons, 2D polylines, 3D NURBS curves created with the **Compose** command, and open 3D polygons.

Occasionally, surface creation methods like the **Create Surface from Curves** command can create a surface with internal discontinuities. Many of

the 3D Power Pack tools and commands are not designed to work with these types of surfaces. The **Decompose** command can separate the surface into NURBS surfaces without discontinuities.

To decompose a NURBS surface:

1. Select the NURBS surface to be decomposed.

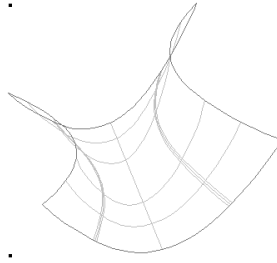

2. Select **Tool > Decompose**.

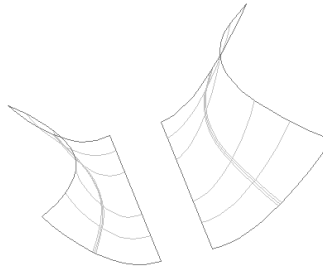

One section moved for clarity

The NURBS surface is separated into individual surfaces.



## Splitting NURBS Surfaces

The **Split** tool now includes NURBS surfaces among the objects that it can split.

**Note:** *Surfaces generated by successive splitting can be joined together with the **Compose** command (see “Composing Surfaces” on page 1-25).*

*This command may not be able to manipulate certain types of surface geometry (see “Surface Geometry Requirements” on page 1-7).*

Select the mode from the Mode bar.



### Point Split Mode

To split a NURBS surface in point split mode:

1. Click the **Split** tool from the Editing palette.
2. Click the **Point Split** mode from the Mode bar.
3. In Wireframe view, click on the NURBS surface to split.

**Note:** See “Selecting the Edges and Faces of a Solid” on page 1-3 for information on selecting surfaces.

Click to select the NURBS surface

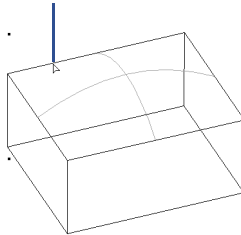

The selected surface is split at that point

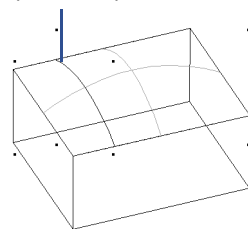

The surface is split by iso-parametric curves passing through the click point along u and v parametric directions.

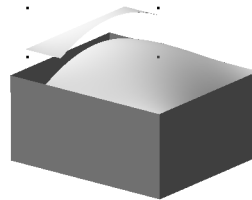

The smaller surface has been moved for clarity

**Note:** If the point is on an existing iso-parametric curve, the surface is split in both directions (u and v).

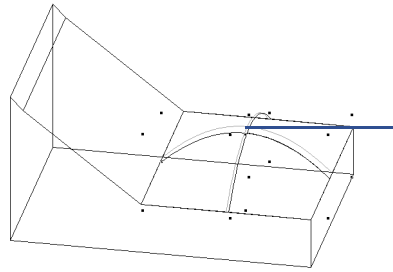

Clicking once on the iso-parametric curve (shown in light gray) with the **Split** tool creates four split surfaces (in black)

### **Line Split Mode**

To split a NURBS surface in line split mode:

1. Click the **Split** tool from the Editing palette.
2. Click the **Line Split** mode from the Mode bar.
3. Draw a line to split the NURBS surface.

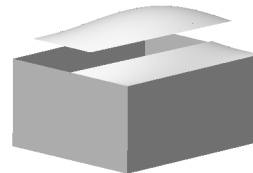
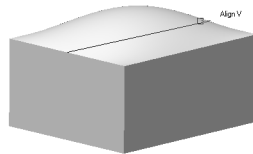

One split surface has been moved for clarity

The surface is split by the line.

**Note:** Solids can also be split in **Line Split** mode. Two Section Solid objects will result.

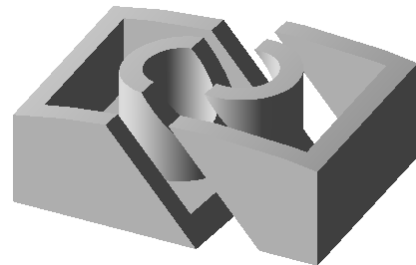
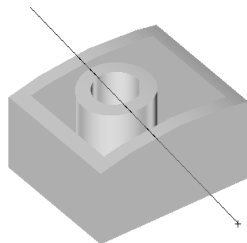

One solid section has been moved for clarity

## NURBS Surface-Curve Interaction

### Trimming NURBS Surfaces with a Projection



Project and Trim  
Tool

The **Project and Trim** tool projects a 2D object or NURBS curve onto a NURBS surface, and then trims the NURBS surface according to the region selected. This allows nonlinear trimming of surfaces to create different shapes or cutting a hole in an object.

To trim a NURBS surface with a projection:

1. In the desired view, draw a 2D object or NURBS curve on top of a NURBS surface.

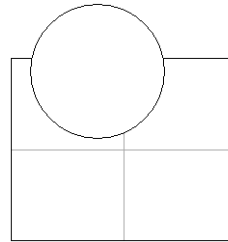

**Note:** *If the object to be projected is an open NURBS curve, both end points must be outside the NURBS surface.*

2. Click the **Project and Trim** tool from the 3D Tools palette.
3. Click on the trimming object, and then click on the NURBS surface. The cursor changes into the pointing hand cursor. Click on the side of the intersection to be trimmed away.

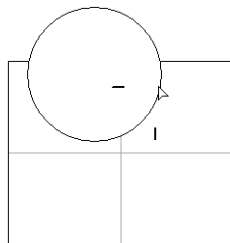

Select the project and  
trimming object

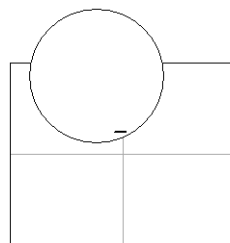

Select the NURBS surface

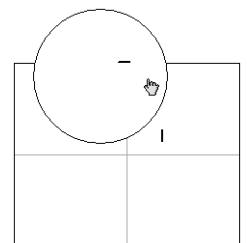

Select the region to be  
trimmed

The trimming object is projected onto the NURBS surface, and the region selected to be trimmed away is removed from the NURBS surface at the point of intersection.

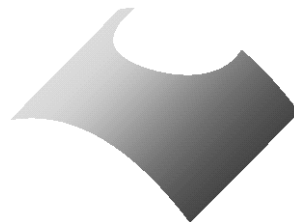
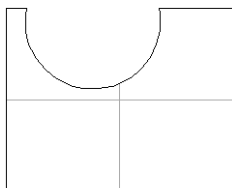

## Solids Operations

### Blending Edges



Blend Edge Tool

The **Blend Edge** tool removes the sharp corners of a solid by blending the edges. The edge can be blended by either a *fillet* (blending by a surface with a circular cross section) or a *chamfer* (blending by a surface with a linear cross section).

Edges are usually blended during the detailed design phase of a project. This may reduce the heat and/or stress concentration in manufacturing and can provide a more realistic or aesthetic appearance to a model.

To blend the edges of a solid:

1. Click the **Blend Edge** tool from the 3D Tools palette.
2. Specify the blend edge preferences by clicking the Preferences button on the Mode bar. The Blend Edge Preferences dialog box opens.

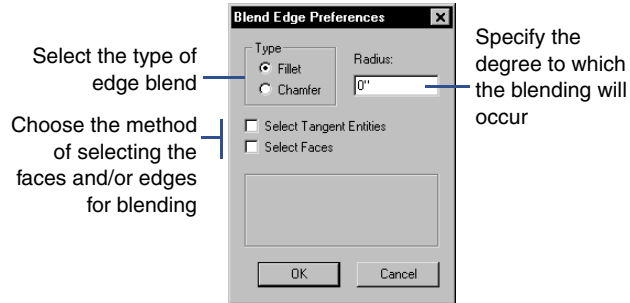

Parameter	Description
Type	Select <b>Fillet</b> (smooth transition between surfaces) or <b>Chamfer</b> (planar surface between the faces) as the blend type
Radius/Setback	When fillet is selected, indicate the <b>Radius</b> of the fillet surface; for Chamfer blends, specify the distance by which the faces are set back ( <b>Setback</b> )
Select Tangent Entities	Choose this option to select tangentially-connected edges and faces for blending
Select Faces	Choose this option to select faces for blending

3. Click **OK** to close the Blend Edge Preferences dialog box.
4. For tangent entity selections, select the tangentially-connected edges and faces to be blended. For face selections, select the faces to be blended. Hold the Shift key down to select several faces and edges.

**Note:** See “Selecting the Edges and Faces of a Solid” on page 1-3 for information on selecting edges and faces.

5. Press Enter (Win) or Return (Mac) or the check mark button on the Mode bar to perform the edge blend.

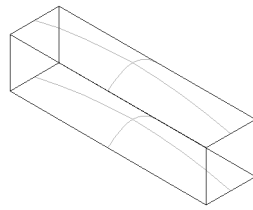

Wireframe – before blending

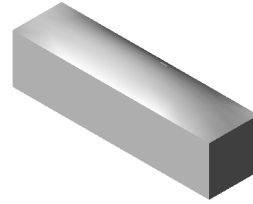

Rendered – before blending

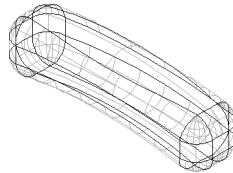

Wireframe – after blending



Rendered – after blending

The blended edge radius or setback value can be edited through the Object Info palette.

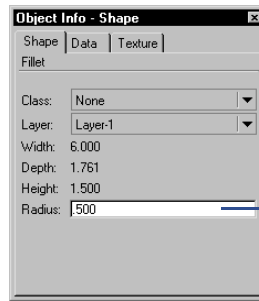

Edit the radius for fillet blends or the setback distance for chamfer blends

**Note:** *Once the blend is created, the edge set used to create the blend cannot be changed. The blend can be ungrouped, and a new blend with different edges can be created.*

*If a blend has been created over another blend, the first blend cannot be edited in the Object Info palette unless the blends are first ungrouped (see “Editing a Fillet/Chamfer or Shell Object” on page 1-6).*

A blend edge operation may fail due to:

- complex surface geometry adjacent to an edge or corner involved in the blend;
- a radius value that is too large;

- an attempt to blend one edge in a sequence of tangential edges (select all the edges for a better chance of success); or
- an attempt to blend without selecting all the edges in a vertex.

## Creating a Shell from a Solid Object



Shell Solid Tool

The **Shell Solid** tool creates a hollow shell from a solid object. The shell can be created outside the solid or inside. Most injection-molded plastic parts have a shell.

To create a shell solid from a solid object:

1. Click **Shell Solid** from the 3D Tools palette.
2. Click on the face of the solid object to create the shell into.

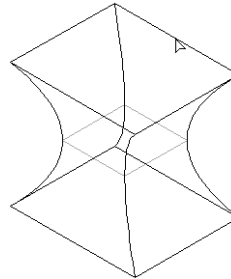

The Shell Solid Preferences dialog box opens.

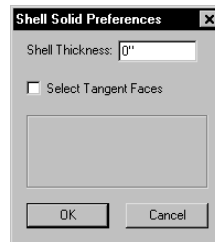

- Specify the desired shell settings.

Parameter	Description
Shell Thickness	Enter the thickness of the shell wall. The distance is calculated from the edge of the selected face. A negative number creates an interior shell; a positive number creates an exterior shell. The edges of an exterior shell are automatically blended.
Select Tangent Faces	Selects the tangentially-connected chain of faces

**Note:** Click the *Shell Solid Preferences* button on the *Mode bar* to edit settings.

- Click **OK**.

The selected face of the object is highlighted in red.

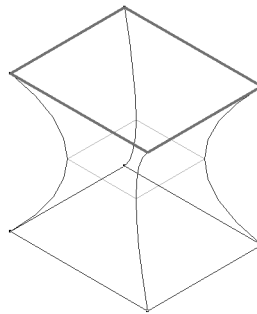

- Press Enter (Win) or Return (Mac), or the check mark button on the *Mode bar*, to create the shell.

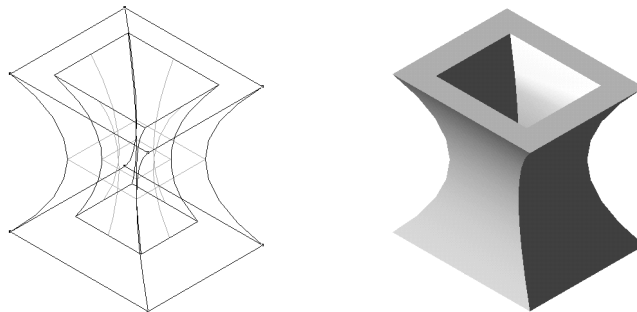

**Note:** If the wrong face is highlighted, select the correct face before pressing Enter.

## Creating a Tapered Extrude

A tapered extrude can now be created from 3D polygons and NURBS curves, circles, and arcs, in addition to the 2D objects previously supported. This command easily creates wavy extrusions by entering a taper value of zero.

To create a tapered extrude:

1. Select the object to turn into a tapered extrude.

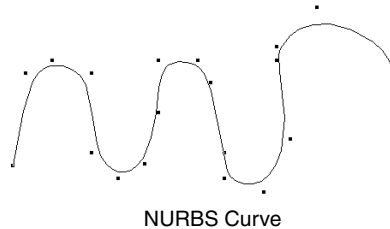

2. Select **Model > Tapered Extrude**.

The Set Tapered Angle and Extrude Height dialog box opens.

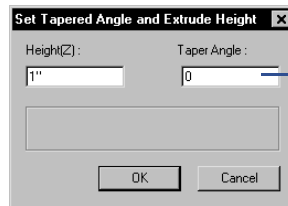

Set a **Taper Angle** of 0 to create an extrusion with no taper

3. Enter the **Height (Z)** of the extrude and the **Taper Angle**.
4. Click **OK** to create the tapered extrude.

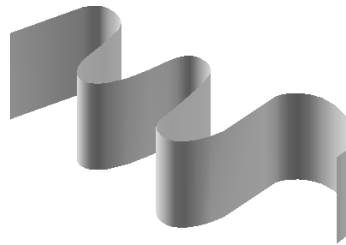

## Stitching and Trimming Surfaces

The **Stitch and Trim Surfaces** command creates a group of trimmed NURBS surfaces from several intersecting surfaces (including NURBS surfaces or solids such as extrudes or sweeps).

**Note:** *This command may not be able to manipulate certain types of surface geometry. See “Surface Geometry Requirements” on page 1-7.*

To stitch and trim intersecting surfaces:

1. Select the intersecting surfaces.

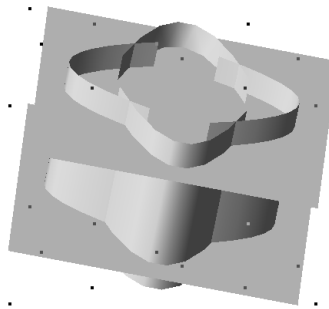

**Note:** *The surfaces must enclose a volume.*

2. Select **Model > Stitch and Trim Surfaces**.

The surfaces enclosing the volume are stitched together and then trimmed, resulting in a group of trimmed NURBS surfaces.

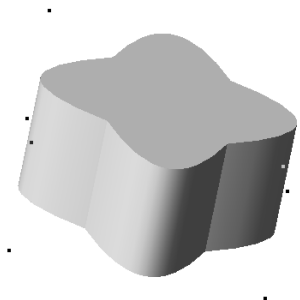

## Sectioning Solids

The **Section Solids** command discards a portion of solids or NURBS surfaces, allowing the creation of planar or stepped sections through a solid or surface. The sectioned surface can be “marked” by the sectioning surface color.

To section a solid:

1. Select the solid or surface to be sectioned, along with the sectioning surface.

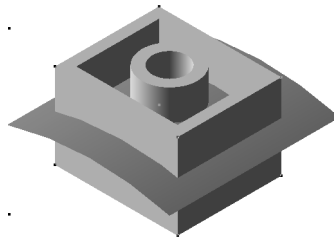

2. Select **Model > Section Solids**. In the Select Object dialog box, specify which object is to be used as the sectioning surface. By default, the most recently created object is highlighted, but a different object can be selected by clicking the arrows.

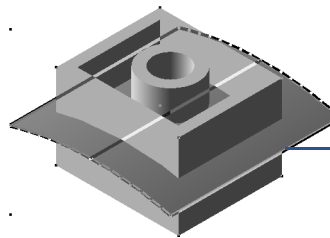
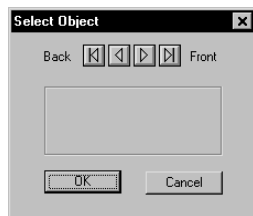

The sectioning surface is highlighted (select it with the arrows in the dialog box)

**Note:** *The sectioning surface must be larger than the solid being sectioned.*

3. When the desired sectioning surface is selected, click **OK**.

The solid is sectioned by the sectioning surface. The remaining object becomes a solid section.

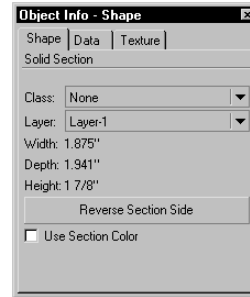
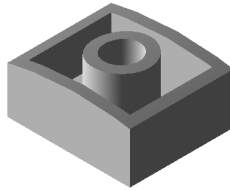

Parameter	Description
Width/Depth/Height (Display only)	Displays the parameters of the solid section surface
Reverse Section Side	Switches the remaining side of the solid being sectioned
Use Section Color	Applies the color of the sectioning surface to the sectioned surface

## Exporting in 3D Power Pack

### Exporting in IGES Format (3D only)

A new export capability has been added to VectorWorks with the 3D Power Pack. The **Export IGES (3D only)** command exports 3D curves, surfaces and solids from VectorWorks into IGES format (version 5.3). Closed solids are exported as solids, while open solids are exported as a collection of surfaces.

Objects that are exported to an \*.igs file from VectorWorks include:

- Groups
- Symbols
- Parametric objects
- NURBS curves and surfaces
- Solids (sphere/cone/hemisphere)
- Extrudes and multiple extrudes
- Sweeps
- CSG solids (add/subtract/intersect/section)

- Fillet
- Chamfer
- Shell
- 3D polygons

To export a file to the IGES format:

1. Select **File > Export > Export IGES (3D only)**.

The Export IGES Options dialog box opens.

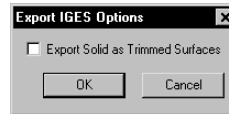

2. To export solids as trimmed surfaces, select the checkbox, and then click **OK**.
3. Specify the file name and destination. Click **Save**.

**If the exported item is a:**

NURBS curve  
NURBS surface  
Trimmed NURBS surface  
Closed solid

**It is exported as an:**

IGES Entity Type 126  
IGES Entity Type 128  
IGES Entity Type 144  
IGES Entity Type 186

# Extracting Curves From Solids

2

This tutorial explains the basics of extracting curves from a solid.

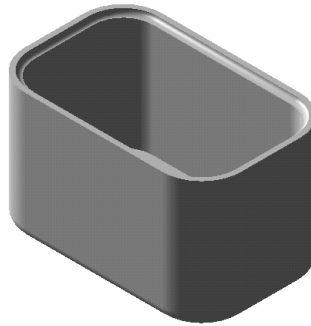

## In this Tutorial:

- Setting Up the Modeling Units
- Creating a Block
- Blending Edges
- Hollowing Out the Block
- Extracting Curves
- Creating the Groove

## Setting Up the Modeling Units

This tutorial works in inches.

To set up the units for modeling distances in inches:

1. Select **Page > Units**.
2. In the Units dialog box, select Inches from the **Unit Name** pulldown menu.

All distances entered for designs will now be in inches.

## Creating a Block



Rectangle  
Tool

1. Double-click the **Rectangle** tool from the 2D Tools palette.

The rectangle object properties dialog box opens.  
Enter the following settings:

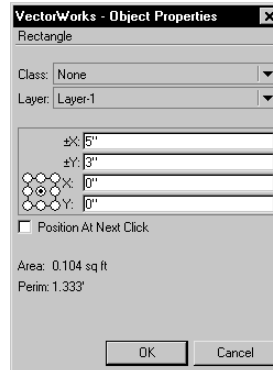

2. Click **OK** to place.

A rectangle is placed in the center of the drawing area.

3. Extrude the rectangle. With the square selected, click **Model > Extrude**. In the Create Extrude dialog box, enter 3" for the **Extrusion** value. Click **OK** to create an extrude object.

## Blending Edges

1. Select **View > Standard Views > Right Isometric**.
2. Click the **Blend Edge** tool from the 3D Tools palette.
3. Click on one of the vertical edges of the block.

The Blend Edge Preferences dialog box opens.

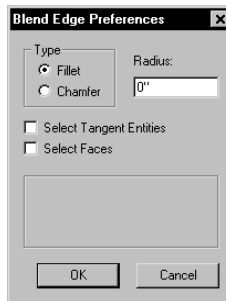

4. Enter 3/4" for the **Radius**, and then click **OK**.
5. Holding the Shift key down, select all of the vertical edges of the block.

Each edge will change to red as it is selected.

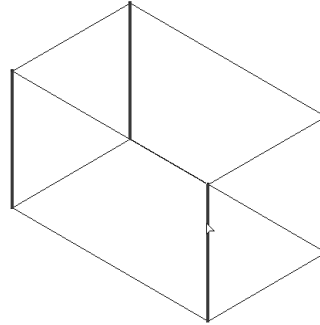

6. Press Enter (Win) or Return (Mac) or the check mark button on the Mode bar.

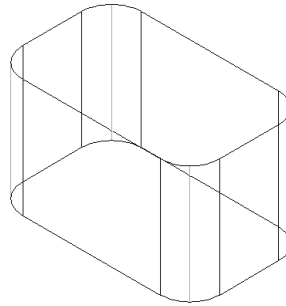

## Hollowing Out the Block



Shell Solid  
Tool

1. Click the **Shell Solid** tool from the 3D Tools palette.
2. Click on the top face of the block.

The Shell Solid Preferences dialog box opens.

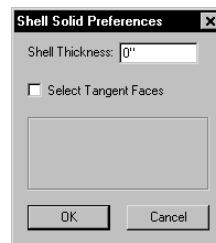

3. Enter 1/4" as the **Shell Thickness**, and then click **OK**.

The top face of the block is highlighted in red.

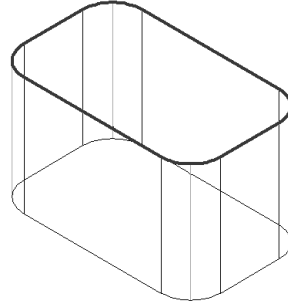

4. Press Enter (Win) or Return (Mac) or the check mark button on the Mode bar to create the shell.

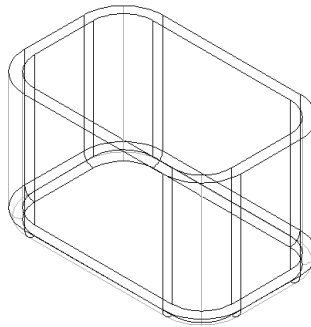

## Extracting Curves

1. Click the **Extract Curve** tool from the 3D Tools palette.
2. Holding the Shift key down, select all of the top inner edges of the block.



Extract Curve  
Tool

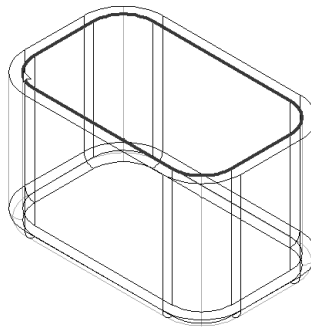

3. Press Enter (Win) or Return (Mac) or the check mark button on the Mode bar.
4. Select **Organize > Ungroup**.
5. Select **Tool > Compose**.

## Creating the Groove



Ellipse  
Tool

1. Click the **Ellipse** tool from the 2D Tools palette, and then select the **Circle by Radius** mode from the Mode bar.
2. In an unused area of the drawing, create a circle with a 1/8" radius.
3. Holding the Shift key, select the circle and the red NURBS curve created earlier.
4. Select **Model > Extrude Along Path**.

The Select Path Object dialog box opens.

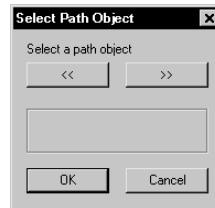

5. Use the arrow buttons to select the NURBS curve as the path object, and then click **OK**.

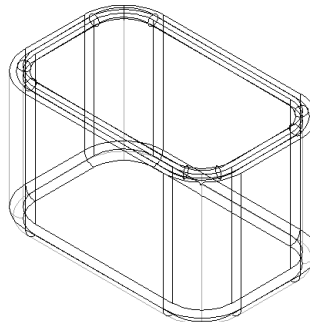

6. Holding down the Shift key, select the block and the extruded-along-path object.

7. Select **Model > Subtract Solids**.

The Select Object dialog box opens.

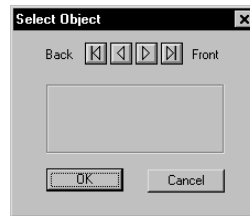

8. Use the arrow buttons to select the block, and then click **OK** to create the groove.

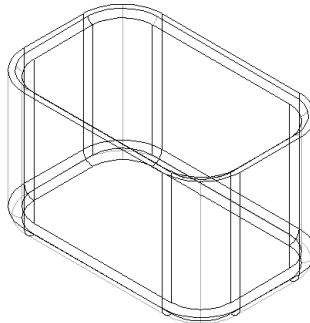

Light Tool

9. To render the model, use the **Light** tool from the 3D Tools palette to insert a light source, and then select **View > Rendering > OpenGL**.

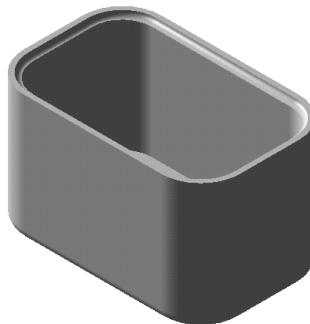

# Creating and Modifying NURBS Surfaces

3

In this tutorial, the body of a telephone handset is created to learn the basics of creating and modifying NURBS surfaces.



## In this Tutorial:

- Setting Up the Modeling Units
- Creating a Block
- Creating NURBS Surfaces
- Reshaping the NURBS Surface
- Creating the Solid
- Smoothing the Edges

## Setting Up the Modeling Units

This tutorial works in inches.

To set up the units for modeling distances in inches:

1. Select **Page > Units**.
2. In the Units dialog box, select Inches from the **Unit Name** pulldown menu.

All distances entered for designs will now be in inches.

## Creating a Block



Rectangle  
Tool

1. Click the **Rectangle** tool from the 2D Tools palette and draw a 6"x1.5" rectangle.
2. Extrude the rectangle. With the rectangle selected, click **Model > Extrude**. In the Create Extrude dialog box, enter 1.5" for the **Extrusion** value. Click **OK** to create an extrude object.

### Creating NURBS Surfaces

1. Convert the extrude object to NURBS surfaces using the **Model > Convert to NURBS** command, which creates a group of NURBS surfaces.
2. Select **Organize > Ungroup** to get six individual surfaces for the six faces of the extrusion. Deselect all the surfaces.
3. Change the view to front view by selecting **View > Standard Views > Front**. Draw a marquee box around the top surface to select it. Change the view to right isometric by selecting **View > Standard Views > Right Isometric**. Make sure that the top surface is still selected.
4. Open the Object Info palette. At this point, the NURBS surface properties are as follows:

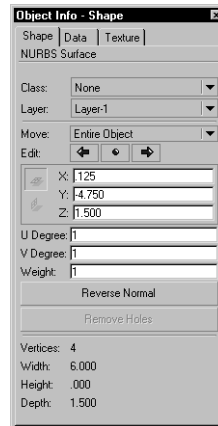

### Reshaping the NURBS Surface

1. In the Object Info palette, change **U Degree** to 2 and **V Degree** to 2. The number of vertices of the selected NURBS surface should now be 9.
2. In **Edit**, click on the arrow(s) until the vertex at the center of the top surface is selected.

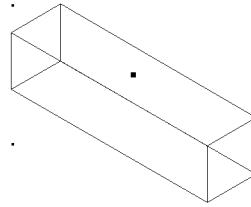

3. From the **Move** pulldown list, select Vertex Only.
4. The **Z** value for the selected vertex is 1.5". Change the **Z** value from 1.5" to 3". The surface becomes dome shaped.

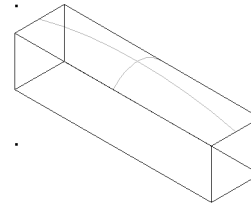

5. Change to front view by selecting **View > Standard Views > Front**. Deselect the top surface and draw a marquee box around the bottom surface to select it.
6. Reshape the bottom surface as described in steps 1 – 4. Change the **Z** value for the vertex at the middle of the bottom surface from 0 to 1.5".

## Creating the Solid

Select all the surfaces and add them together by selecting **Model > Add Solids**.

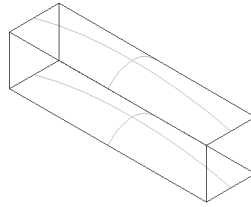

### Smoothing the Edges



Blend Edge Tool

1. Click the **Blend Edge** tool from the 3D Tools palette. Open the Blend Edge Preferences dialog box by clicking on the Preferences button in the Mode bar.

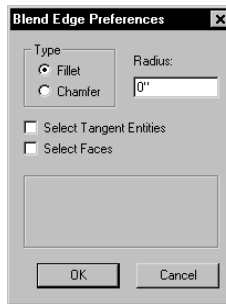

2. Enter 0.5" in the **Radius** field, and then click **OK**.
3. Press the Shift key and select the four vertical edges. Perform the blend by pressing Enter (Win) or Return (Mac) or the check mark button on the Mode bar.

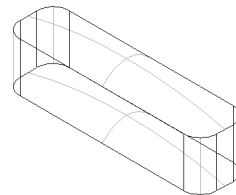
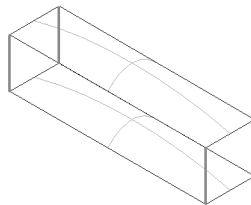

4. Open the Blend Edge Preferences dialog box by clicking the button in the Mode bar. Select the **Select Tangent Entities** checkbox. Enter 0.4" in the **Radius** field, and then click **OK**.

5. Press the Shift key and select the tangential sequence of edges at the top and at the bottom. Press Enter (Win) or Return (Mac) or the check mark button on the Mode bar to blend the selected edges.

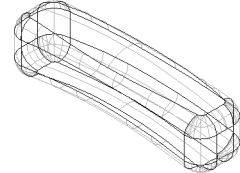
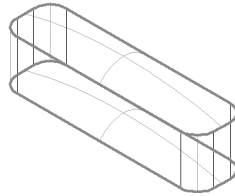

Light Tool

6. To render the model, use the **Light** tool from the 3D Tools palette to insert a light source, and then select **View > Rendering > OpenGL**.

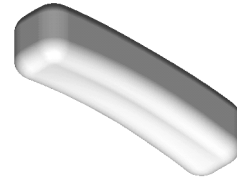

# Creating Surface Models

4

In this tutorial, construct a hat-shaped solid to learn how to create and modify NURBS surfaces and perform surface trimming.

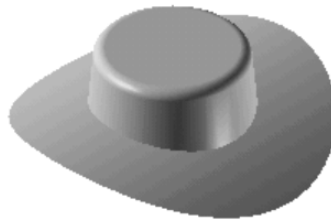

## In this Tutorial:

- Setting Up the Modeling Units
- Creating a Flat NURBS Surface
- Reshaping the NURBS Surface
- Creating a Trimmed Surface
- Creating the Hat Shape

## Setting Up the Modeling Units

This tutorial works in inches.

To set up the units for modeling distances in inches:

1. Select **Page > Units**.
2. In the Units dialog box, select Inches from the **Unit Name** pulldown menu.

All distances entered for designs will now be in inches.

## Creating a Flat NURBS Surface

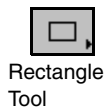

1. Click the **Rectangle** tool from the 2D Tools palette and draw a 6" x 6" square in the center of the drawing area.

2. Extrude the square. With the square selected, click **Model > Extrude**. In the Create Extrude dialog box, enter 0 (zero) for the **Extrusion** value. Click **OK** to create an extrude object with zero height.
3. Select **Model > Convert to NURBS**.  
The extrude object is converted to NURBS surfaces.

### Reshaping the NURBS Surface

1. In the Object Info palette, change both the **U Degree** and **V Degree** values to 2.  
The number of **Vertices** for the selected NURBS surface is now 9.
2. In the **Move** field, select Vertex Only from the pulldown menu.
3. In the **Edit** field, press the arrow key until one of the vertices in the center “column” is highlighted. Change the **Z** value to 2. Repeat this process to highlight and change the **Z** value of each of the remaining two vertices in the center “column.” This creates a curvy surface.

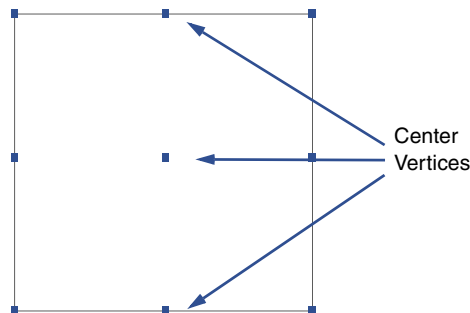

4. Select **View > Standard Views > Right Isometric**.  
The surface displays as follows.

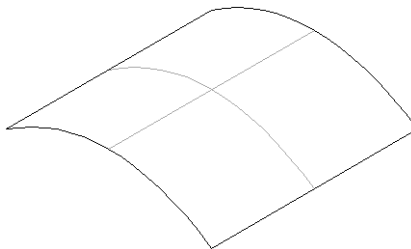

## Creating a Trimmed Surface



Ellipse Tool



Project and Trim Tool

1. Select **View > Standard Views > Top** to change to drawing view.
2. Click the **Ellipse** tool from the 2D Tools palette, and then select the **Circle by Radius** mode from the Mode bar.
3. Draw a circle at the center of the NURBS surface with a 2.75" radius.
4. Click the **Project and Trim** tool from the 3D Tools palette. Select the circle, select the surface, and then indicate the region outside the circle to be trimmed away.

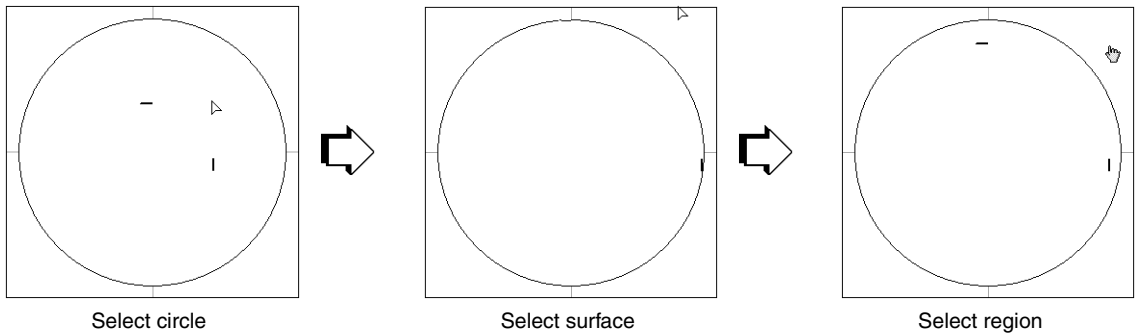

5. Select **View > Standard Views > Right Isometric**.

The surface displays as follows.

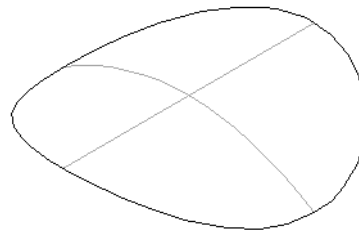

## Creating the Hat Shape



Ellipse Tool

1. Select **View > Standard Views > Top**.
2. Click the **Ellipse** tool from the 2D Tools palette, and then select the **Circle by Radius** mode from the Mode bar.
3. Draw a circle at the center of the NURBS surface with a 1.5" radius.

4. Select the circle, and then select **Model > Tapered Extrude**.

The Set Tapered Angle and Extrude Height dialog box opens.

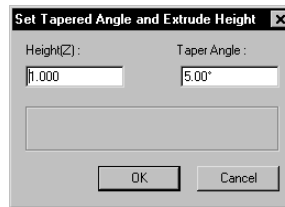

5. Enter a 2” **Height(Z)**, leave the **Taper Angle** value as is, and then click **OK**.

A tapered extrude object is created.

6. Select **Edit > Select All**. Select **Model > Add Solids** to add the tapered extrusion to the NURBS surface.

7. To render the model, use the **Light** tool from the 3D Tools palette to insert a light source, and then select **View > Rendering > OpenGL**.

8. Click the **Flyover** tool from the 3D Tools palette and click-drag until the hat displays as follows.

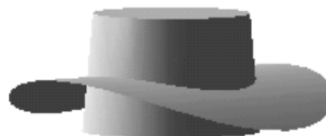

9. With the hat selected, click **Model > Convert to NURBS** to convert all the surfaces of the solid to NURBS surfaces. Select **Organize > Ungroup** to display all individual surfaces.
10. Select **View > Rendering > Wireframe** to switch to wireframe view.

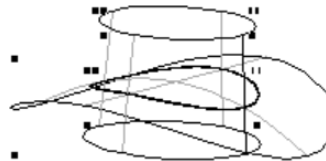

- Click on the drawing area to deselect the objects. Delete the two surfaces underneath the big round surface.

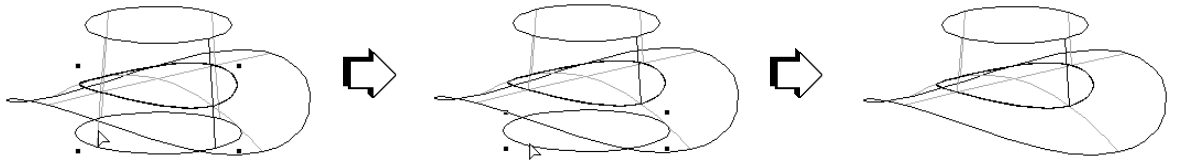

- Delete the surface at the middle of the big round surface, thus creating a hole in the big round surface.

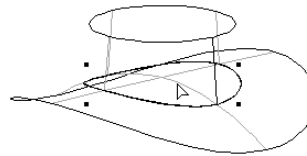

**Note:** You may have to draw a marquee box around the surface in order to select it.

At this point there are three surfaces.

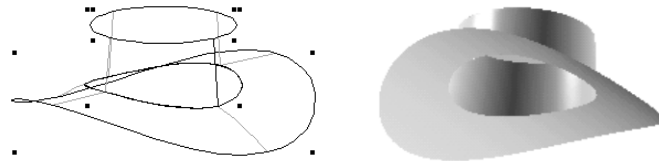

- From the Attributes palette, assign colors to the surfaces, as indicated.

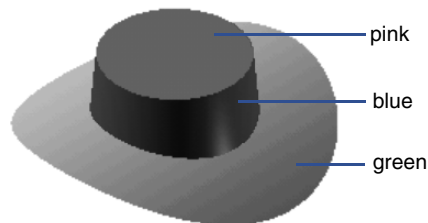

- Select **Edit > Select All**. Select **Model > Add Solids** to add the surfaces together.

- Click the **Blend Edge** tool from the 3D Tools palette.

- Select the top edge of the hat.



The Blend Edge Preferences dialog box opens.

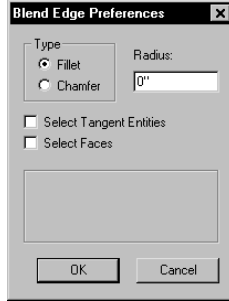

17. Enter 0.2" in the **Radius/Setback** field, and then click **OK**.
18. Press Enter (Win) or Return (Mac) or the check mark button on the Mode bar to blend the edges.

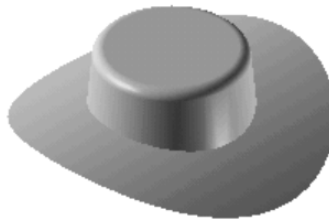

# Creating and Modifying Free-form Shapes

5

In this tutorial, you will construct a vase in order to learn the basics of creating and modifying free-form shapes.

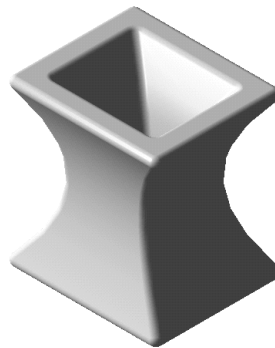

## In this Tutorial:

- Setting Up the Modeling Units
- Creating the Cross Sections
- Setting Up the Cross Section
- Creating the Vase Shape
- Hollowing Out the Vase
- Blending the Edges

## Setting Up the Modeling Units

This tutorial works in inches.

To set up the units for modeling distances in inches:

1. Select **Page > Units**.
2. In the Units dialog box, select Inches from the **Unit Name** pulldown menu.

All distances entered for designs will now be in inches.

## Creating the Cross Sections

To create the cross sections:

1. From the **View** bar, click **Fit to Window**.
2. Click the **Rectangle** tool from the 2D Tools palette.



Rectangle  
Tool

3. Click on the lower left side of the drawing area, and then press Tab to highlight the **+/-X** field. Enter 6", and then press Enter (Win) or Return (Mac).
4. Press Tab until the **+/-Y** field is highlighted. Enter 5", and then press Enter (Win) or Return (Mac). Click on the drawing area to set the rectangle.
5. With the rectangle still highlighted, select **Edit > Copy**.
6. Select **Edit > Paste**.  
A copy of the rectangle is placed on the drawing.
7. Select the **Rectangle** tool.
8. Click on the drawing, and then press Tab to highlight the **+/-X** field. Enter 3", and then press Enter (Win) or Return (Mac). Press Tab until the **+/-Y** field is highlighted. Enter 3", and then press Enter (Win) or Return (Mac). Click on the drawing area to set the square.

A square is created.

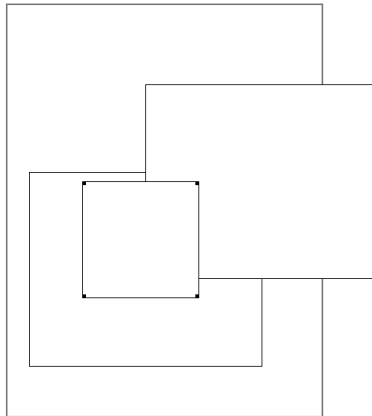

## Setting Up the Cross Section

To set up the cross section:

1. Click the **2D Selection** tool from the 2D Tools palette.
2. Select **Edit > Select All**.
3. Select **Model > Convert to NURBS**.

4. Select **Organize > Ungroup**.
5. Deselect the rectangles by clicking on a unused area of the drawing.
6. Select **Palettes > Object Info**.  
The Object Info palette opens.
7. Select one of the two larger rectangles.
8. In the Object Info palette, enter 3” for the **Z** value.

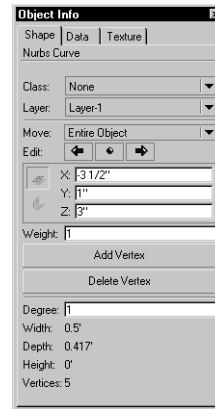

9. Select the other large rectangle, and then enter -3” for the **Z** value in the Object Info palette.
10. Click on the drawing area, and then select **Edit > Select All**.
11. Select **Tool > Align > Align/Distribute**.  
The Align/Distribute Objects dialog box opens.
12. Select **Align** and **Center** for both the vertical and horizontal.

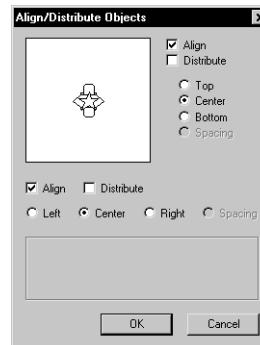

13. Click **OK**.
14. Select **View > Standard Views > Right Isometric**.

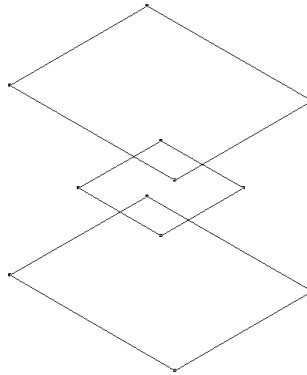

### Creating the Vase Shape



Loft Surface  
Tool

To create the body of the vase:

1. Click the **Loft Surface** tool from the 3D Tools palette.
2. Click on the left corner of the bottom square, and then click on the left corner of the middle rectangle.

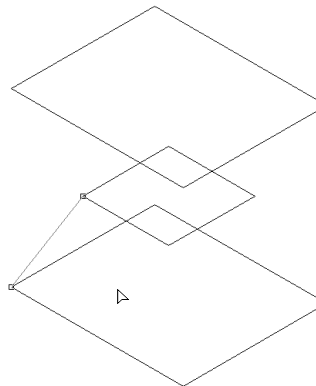

The two corners are connected by a red line representing the beginning of proposed curve.

3. Click on the left corner of the top square.

The loft curve is completed.

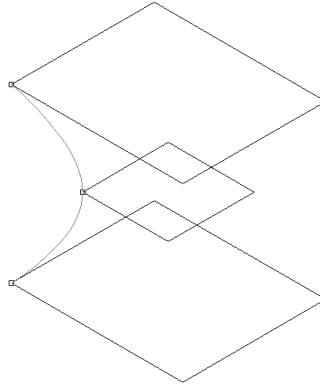

**Note:** *If the wrong connections are selected, double-click on the last point to cancel the operation, and then start again.*

4. Press Enter (Win) or Return (Mac) or the check mark button on the Mode bar to accept the proposed curve.

The Loft Creation dialog box opens.

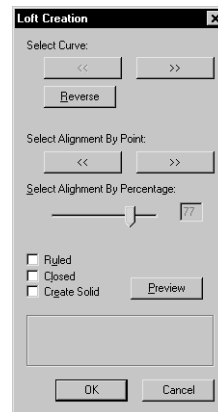

5. Select **Create Solid** and then click **Preview**.

A preview of the final shape is displayed.

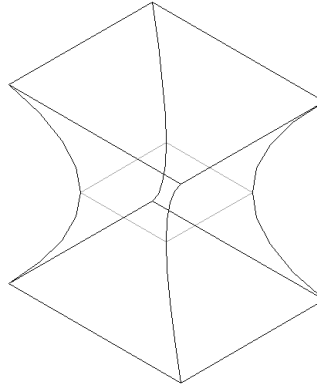

Light Tool

6. Click **OK** to accept the settings.
7. To view the model rendered, use the **Light** tool from the 3D Tools palette to insert a light source, and then select **View > Rendering > OpenGL**.

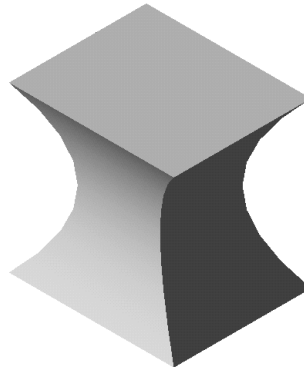

## Hollowing Out the Vase

To hollow out the vase:

1. Select **View > Rendering > Wireframe**.
2. Click the **Shell Solid** tool from the 3D Tools palette.
3. Click on the top face of the vase.



Shell Solid  
Tool

The Shell Solid Preferences dialog box opens.

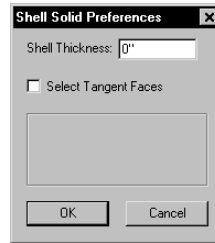

4. Enter  $-3/4$ " as the **Shell Thickness**, and then click **OK**.

The top face of the vase is highlighted in red.

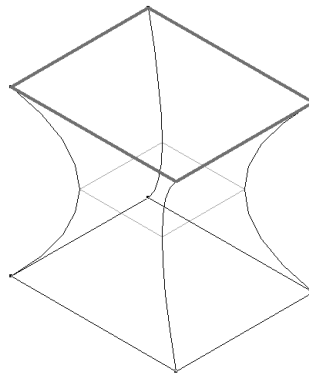

5. Press Enter (Win) or Return (Mac) or the check mark button on the Mode bar to create the shell.

**Note:** *If the wrong face is highlighted, select the correct one before pressing Enter.*

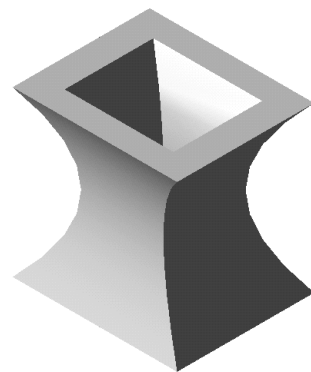
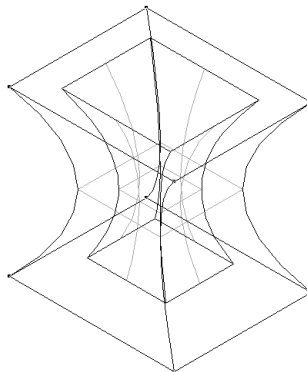

### Blending the Edges

All the edges of the vase can be blended to give them a smoother and rounder appearance.

To blend edges:



Blend Edge  
Tool

1. Select **View > Rendering > Wireframe**.
2. Click the **Blend Edge** tool from the 3D Tools palette.
3. Click on one of the vertical edges of the vase.

The Blend Edge Preferences dialog box opens.

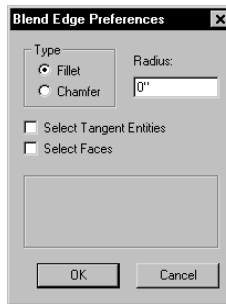

4. Enter 1/4" for the **Radius**, and then click **OK**.
5. Holding the Shift key down, select all of the vertical edges of the vase.

Each edge will change to red as it is selected.

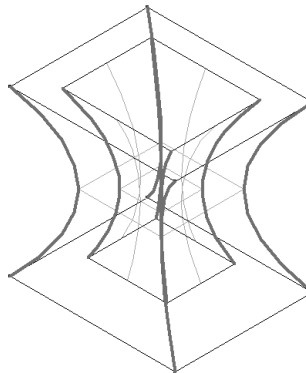

Rotate the drawing using the **Flyover** tool from the 3D Tools palette to make selection easier. To obtain the flyover tool in Boomerang mode,

press spacebar + B. Release the spacebar + B to return to the **Blend Edge** tool.

6. Press Enter (Win) or Return (Mac) or the check mark button on the Mode bar to accept the selections and blend the edges.

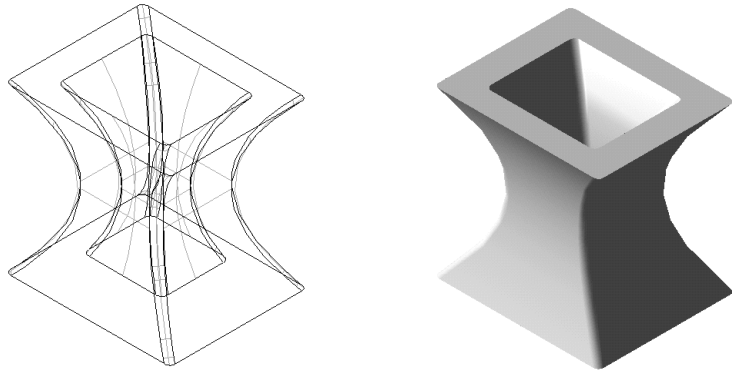

7. Click the **Blend Edge Preferences** button on the Mode bar.  
The Blend Edge Preferences dialog box opens.
8. Enter 1/5" for the **Radius** and select the **Select Tangent Entities** checkbox.
9. Click **OK**.
10. Holding the Shift key, select the tangentially-connected chain of edges.

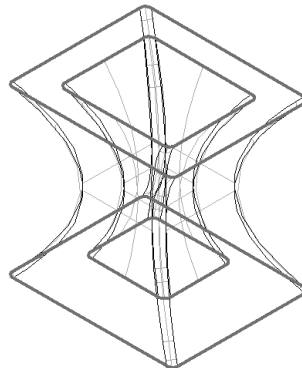

11. Press Enter (Win) or Return (Mac) or the check mark button on the Mode bar to blend the edges.

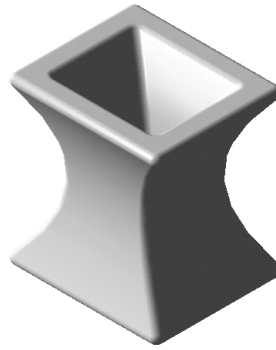
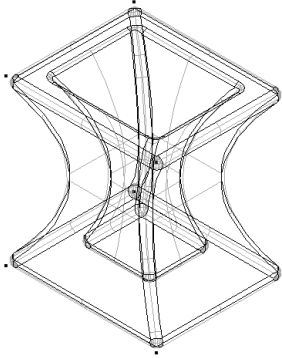

# Sectioning Solids

6

This tutorial covers the basics of sectioning solids by creating a mallet head.

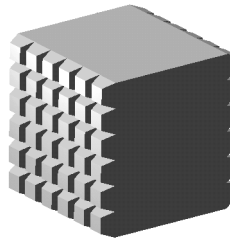

## In this Tutorial:

- Setting Up the Modeling Units
- Creating a Block
- Creating the Sectioning Surfaces
- Sectioning the Solid

## Setting Up the Modeling Units

This tutorial works in inches.

To set up the units for modeling distances in inches:

1. Select **Page > Units**.
2. In the Units dialog box, select Inches from the **Unit Name** pulldown menu.

All distances entered for designs will now be in inches.

## Creating a Block



Rectangle  
Tool

1. Click the **Rectangle** tool from the 2D Tools palette and draw a 6" x 6" square.
2. Extrude the square. With the square selected, click **Model > Extrude**. In the Create Extrude dialog box, enter 6" for the **Extrusion** value. Click **OK** to create an extrude object.

## Creating the Sectioning Surfaces

Now create the surfaces that will serve as the sectioning surfaces for the mallet head.



2D Polygon Tool

### Creating and Extruding the Polygon

1. At the top left corner of the extrude, use the **2D Polygon** tool (located on the 2D Tools palette) to draw a polygon with the dimensions shown below.

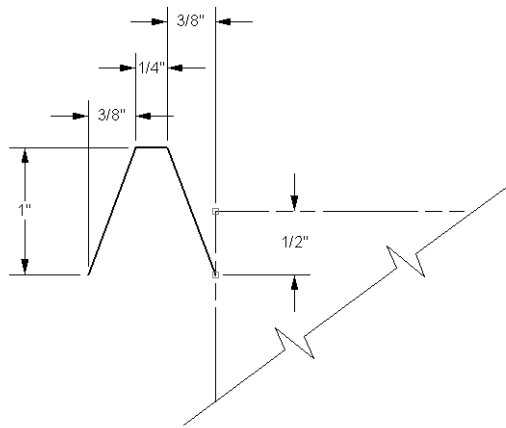

2. Select the polygon, and then click **Edit > Duplicate Array** command. The Duplicate dialog box opens. Make the following settings:

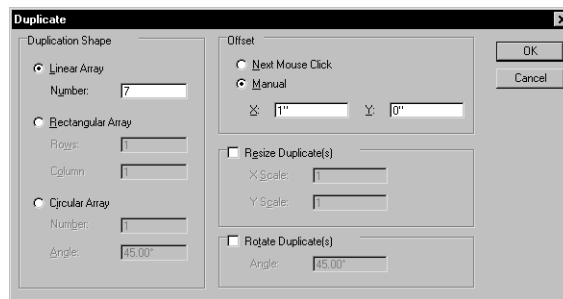

2D Selection Tool

3. Click **OK** to duplicate the original polygon seven times, offset by 1" in the X direction. Select all the polygons by drawing a marquee around them with the **2D Selection** tool (located on the 2D Tools palette).

4. Compose the polygons into a single polygon by selecting **Tool > Compose**.

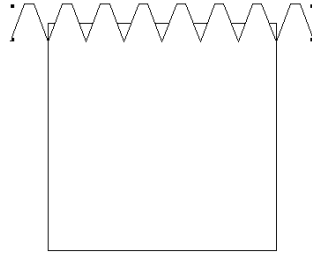

5. Extrude the polygon. With the composed polygon selected, click **Model > Extrude**. In the Create Extrude dialog box, enter 8" for the **Extrusion** value. Click **OK** to create an extrude object.
6. Move the extrude object down by selecting **Tool > Move > Move 3D** and entering -1" for **Z Offset**.

## Creating the Sectioning Surfaces

1. Convert the extrusion to NURBS surfaces by selecting **Model > Convert to NURBS**. Ungroup the NURBS surfaces by selecting **Organize > Ungroup**.
2. Add the surfaces by selecting **Model > Add Solids**. The solid that is created will be used as the sectioning surface. Select **View > Standard Views > Right Isometric** to view the objects in 3D.

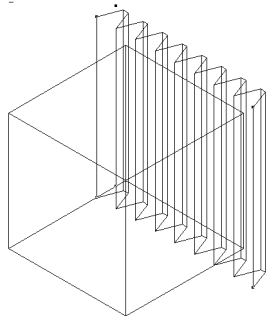

- Copy the selected sectioning surface by clicking **Edit > Copy**, and then paste the copy with the **Edit > Paste in Place** command. Rotate the selected copy by selecting **Tool > Rotate > Rotate 3D**. Enter the following parameters:

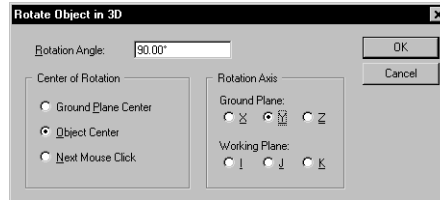

The copy of the sectioning surface is rotated 90° from the original. There are now two sectioning surfaces.

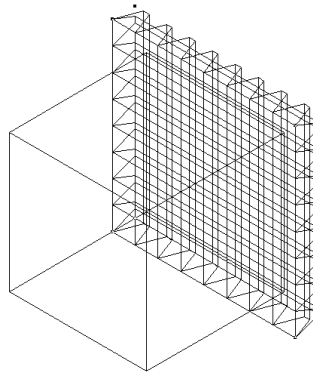

- The two sectioning surfaces will be mirrored to create four sectioning surfaces, with each pair on opposite sides of the mallet head. Switch to Top view by selecting **View > Standard Views > Top**.
- In the center of the rectangle, draw a guide line (using the **Line** tool from the 2D Tools palette) to serve as a guide for mirroring.



Line Tool

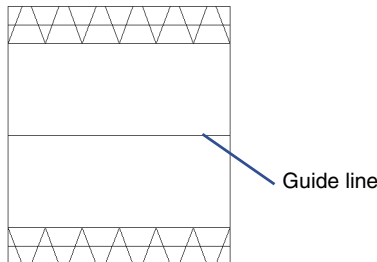



- With both sectioning surfaces selected, click the **3D Mirror** tool from the 3D Tools palette. In **Duplicate and Mirror** mode, draw the axis line over the guide line. Delete the guide line.

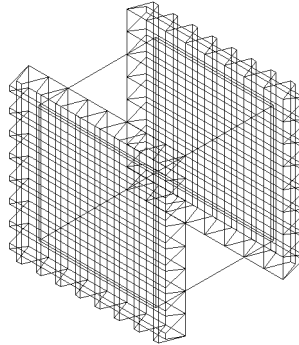

Switch the view by selecting **View > Standard Views > Right Isometric**. There are now four sectioning surfaces, with two on each side of the block.

## Sectioning the Solid

- Select the block and one of the sectioning surfaces. Select **Model > Section Solids**. Ensure that the selection surface is highlighted (if it is not, use the arrow keys to select it).

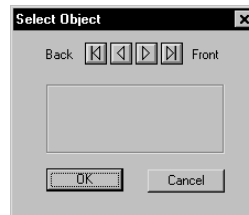

- Click **OK** to section the solid with the sectioning surface. If sectioning produced the incorrect part of the block, click **Reverse Section Side** from the Object Info palette.

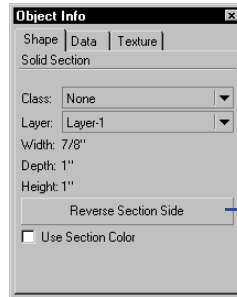

If necessary, click to keep the relevant portion of the block

3. Repeat the sectioning procedure with the remaining three sectioning surfaces. The mallet head is complete.

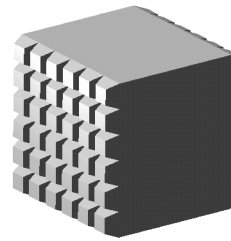
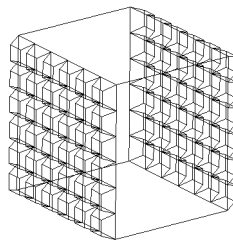

# Index

## Numerics

3D Reshape tool 1-21

## B

Blend Edge tool 1-30

Boomerang mode 1-2

## C

Chamfer blend 1-30

Compatibility 1-3

Compose command 1-25

Connect/Combine tool 1-9

Contours, creating 1-8

Convert to NURBS command 1-11

Create Contours tool 1-8

Create Fillet Surface command 1-19

Create Planar Caps command 1-20

Create Surface from Curves command 1-16

Creating

    contours 1-8

    fillet surface 1-19

    loft surface 1-13

    NURBS surface 1-16

    shell 1-33

    tapered extrude 1-35

    trimmed surfaces 1-36

Cursor

    Power pack 1-3

Curve matching 1-9

## D

Decompose command 1-25

## E

Edges, selecting 1-4

Editing

    blend 1-32

Exporting

    IGES format 1-38

Extract Curve tool 1-7

Extract Surface tool 1-12

Extrude, tapered 1-35

## F

Faces, selecting 1-5

Features 1-1

Fillet blend 1-30

Fillet surface 1-19

## I

IGES export 1-38

## L

Loft Surface tool 1-13

## N

NURBS 1-1

    composing 1-25

    connecting & combining 1-9

    converting to 1-11

    creating 1-16

    decomposing 1-25

    extracting curve 1-7

    extracting surface 1-12

    loft surface 1-13

    planar caps 1-20

    project and trim 1-29

    reshaping 1-21

    sectioning 1-37

    splitting by line 1-28

    splitting by point 1-27

    surface properties 1-23

    tapered extrude 1-35

---

trimming 1-29

## O

Objects

cutting hole 1-29

## P

Power pack

cursors 1-3

overview 1-1

Project and Trim tool 1-29

Properties

NURBS surface 1-23

## R

Reshaping

NURBS surfaces 1-21

## S

Section Solids command 1-37

Selecting

edges and faces 1-3

vertices 1-22

Shell Solid tool 1-33

Solid

blending edges 1-30

capping 1-20

creating shell 1-33

extracting surfaces 1-12

sectioning 1-37

selecting edges & faces 1-3

Split tool 1-26

Stitch and Trim Surfaces command 1-36

Surfaces

stitch & trim 1-36

## T

Tapered extrude 1-35

Tool - 3D

3D reshape 1-21

blend edge 1-30

create contours 1-8

extract curve 1-7

extract surface 1-12

loft surface 1-13

project and trim 1-29

shell solid 1-33

Tool - editing

connect/combine 1-9

split 1-26

Tutorial

creating and modifying NURBS surfaces 3-1

creating curves from solids 2-1

creating free-form shapes 5-1

sectioning solids 6-1

stitching and trimming surfaces 4-1

## V

VectorWorks, previous versions 1-3

Vertices

moving 1-21

selecting 1-22

## W

Workspace 1-1